

# GENERAL DRAINAGE STANDARDS AND REGULATIONS

## TABLE OF CONTENTS

	PAGE
1. POLICY .....	1-2
2. DEFINITIONS .....	2-6
3. DETERMINATION OF RUNOFF CHARACTERISTICS .....	6-9
a. RATIONAL METHOD .....	6-8
b. SOIL CONSERVATION SERVICE METHOD .....	8-9
4. DETERMINATION OF REQUIRED STORAGE VOLUMES .....	9-13
a. RATIONAL METHOD .....	10-11
b. SOIL CONSERVATION SERVICE METHOD .....	12-13
5. DESIGN OF STORAGE FACILITIES .....	13-18
a. GENERAL GUIDELINES .....	14
b. WET BOTTOM BASINS .....	14-15
c. DRY BOTTOM BASINS .....	15
d. OTHER FACILITIES .....	15-18
- PARKING LOTS .....	15-16
- ROOFTOPS .....	16
- INFILTRATION .....	17-18
e. OUTFLOW CONTROL DEVICES .....	18
6. DESIGN FOR VARIOUS PARTS OF A DRAINAGE FACILITY ...	18-20
a. GENERAL REQUIREMENTS .....	18-19
b. CLOSED CONDUIT/STORM SEWER SYSTEMS .....	19-20
7. HYDRAULIC GRADIENT .....	20-22
8. DESIGN FOR OPEN CHANNEL SYSTEMS .....	22-25
a. MANNING'S FORMULA .....	22
b. CHANNEL CROSS SECTION AND GRADE .....	22-23
c. SIDE SLOPES .....	23
d. CHANNEL STABILITY .....	23
e. ADDITIONAL DRAINAGE OF WATERWAYS .....	24
f. APPURTENANT STRUCTURES .....	24
g. DISPOSITION OF SPOIL .....	24
h. MATERIALS AND CONSTRUCTION .....	24-25
i. GENERAL REQUIREMENTS .....	25
9. SPECIFICATIONS FOR EROSION CONTROL .....	25-27
a. CONFORMANCE WITH STATE REQUIREMENTS .....	25-26
b. PROTECTION METHODS .....	26-27

TABLE OF CONTENTS - CONTINUED

	PAGE
10. MISCELLANEOUS STANDARDS .....	27-29
a. CONSTRUCTION/MAINTENANCE/INSPECTIONS .....	27-28
b. AS-BUILT PLANS .....	28
c. MISCELLANEOUS STRUCTURES .....	28
- SUMP PUMPS .....	28
- DOWN SPOUTS .....	28
- FOOTING DRAINS .....	28
- BASEMENT FLOOR DRAINS .....	28
11. DISCLAIMER OF LIABILITY .....	28-29
12. EXEMPTION OF PRIOR PLANS .....	29
13. STANDARD STORM FLOW COMPUTATION FORMS .....	29
14. CERTIFICATIONS .....	29
15. VARIANCES .....	29
16. AMENDMENTS .....	29-30
17. REFERENCES .....	30
18. EFFECTIVE DATE .....	30



LIST OF TABLES

	PAGE
TABLE 1 DETERMINATION OF RUNOFF COEFFICIENTS FOR THE RATIONAL METHOD .....	31-32
TABLE 2 REPRESENTATIVE RUNOFF COEFFICIENTS AND INLET TIMES .....	33
TABLE 3 EQUATIONS FOR DETERMINING OVERLAND FLOW TIME .....	34
TABLE 3a VALUES FOR KERBY'S FORMULA .....	34
TABLE 3b MANNING'S ROUGHNESS COEFFICIENT .....	35
TABLE 3c VALUES OF c FOR IZZARD'S FORMULA .....	35
TABLE 4 SCS CLASSIFICATION OF SOILS .....	36
TABLE 5 ANTECEDENT MOISTURE CONDITION CRITERIA .....	36
TABLE 6 HYDROLOGIC SOIL GROUPS FOR INDIANA .....	37-41
TABLE 7 RUNOFF CURVE NUMBERS FOR MISCELLANEOUS AGRICULTURAL LANDS-SCS METHOD .....	42
TABLE 8 RUNOFF CURVE NUMBERS FOR CULTIVATED AGRICULTURAL LANDS-SCS METHOD .....	43
TABLE 9 RUNOFF CURVE NUMBERS FOR URBAN AREAS- SCS METHOD .....	44
TABLE 10 TYPICAL VALUES OF MANNING'S n AND MAXIMUM VELOCITIES .....	45
TABLE 11 VALUES OF MANNING'S n .....	46-50
TABLE 12 COMPUTATIONS OF COMPOSITE ROUGHNESS COEFFICIENTS FOR EXCAVATED AND NATURAL CHANNELS .....	51
TABLE 13 JUNCTION OR STRUCTURE COEFFICIENT OF LOSS ..	52-54
TABLE 14 RAINFALL INTENSITY IN INCHES PER HOUR-MUNCIE/DELAWARE COUNTY .....	55
TABLE 15 RAINFALL DEPTHS IN INCHES- MUNCIE/DELAWARE COUNTY .....	55
TABLE 16 MAXIMUM PERMISSIBLE VELOCITIES IN VEGETAL LINED CHANNELS .....	56

LIST OF FIGURES

	PAGE
FIGURE 1    FREQUENCY-INTENSITY-DURATION CURVE- MUNCIE/DELAWARE COUNTY .....	57
FIGURE 2    SCS CURVE NUMBER DIAGRAM OF ACCUMULATED RAINFALL, RUNOFF & INFILTRATION .....	58
FIGURE 2a    SCS CURVE NUMBER METHOD GRAPHICAL SOLUTION FOR RUNOFF .....	59
FIGURE 3    AVERAGE VELOCITIES FOR ESTIMATING TRAVEL TIME-SCS .....	60
FIGURE 4    COMPUTATION FORM FOR STORAGE CALCULATION- RATIONAL METHOD .....	61
FIGURE 5    COMPUTATION FORM FOR STORAGE CALCULATION- SCS CURVE NUMBER METHOD .....	62
FIGURE 6    TYPICAL RECHARGE TRENCH FOR AN INFILTRATION SYSTEM .....	63
FIGURE 6a    TYPICAL ORIFICE-TYPICAL WEIR .....	64
FIGURE 7    SELECTION OF EROSION CONTROL METHOD BY SLOPE AND DEPTH .....	65
FIGURE 8    STONE BLANKET & TOE TRENCH DETAIL .....	66
FIGURE 9    STONE BLANKET & TOE DETAIL .....	66
FIGURE 10    TERMINAL CUTOFF OF RIP RAP BLANKET .....	67
FIGURE 11    CONCRETE PAVING SLOPE PROTECTION .....	67

APPENDICES

APPENDIX A    COMPUTATION FORMS	
APPENDIX B    CERTIFICATIONS	
APPENDIX C    FREQUENCY CURVES-RECOMMENDED GRADING PLAN-MISC.	
APPENDIX D    BIBLIOGRAPHY-REFERENCES	

## GENERAL DRAINAGE STANDARDS AND REGULATIONS

### 1. POLICY

These General Drainage Standards have been adopted by the Board of Commissioners of Delaware County, Indiana, and authorized by Ordinance Number \_\_\_\_\_.

The purpose of these standards is to reduce the hazard to public health and safety caused by excessive storm water runoff and to protect, promote and conserve the orderly development of land and water resources within Delaware County, Indiana.

It is recognized that, with the possible exception of the major watercourses such as the White River and the Mississinewa River, the smaller streams and drainage channels serving Delaware County, Indiana, do not have sufficient capacity to receive and convey storm water runoff resulting from continued land alterations within the County. Accordingly, the storage and/or controlled release rate of excess storm water runoff shall be required for all new businesses, commercial and industrial developments, subdivisions (residential, commercial or industrial), and any redevelopment or other new construction located within Delaware County in conformance with the Storm Drainage and Sediment Control Ordinance, and all amendments thereto, for Delaware County, Indiana.

The release rate of storm water from development, redevelopment and new construction may not exceed the storm water runoff from the land area in its present state of development. The developer must submit to the County Engineer detailed computations of runoff before and after development, redevelopment or new construction which demonstrate that runoff will not be increased. These computations must show that the peak runoff rate after development for the 50 year return period storm of critical duration shall not exceed the 5 year return period pre-development peak runoff rate. The critical duration storm is that storm duration which requires the greatest detention storage.

Computations may be based upon the Rational Method, the Soil Conservation Service Method and/or hydrograph techniques and other proven computer modelling methods acceptable to the Delaware County Engineer. Certain parameters shall be set by the standards herein and other parameters are, by nature, variable depending on site specifics (i.e. drainage area, number of subbasins, soil type, type of development, etc.). It is recommended that such variable parameters be reviewed with the Delaware County Engineer prior to final design to avoid possible revisions due to design criteria conflicts.

Additionally, because topography and the availability of outlets for storm runoff vary with almost every site, the requirements for storm drainage tend to be an individual matter



for any project. It is also recommended that each proposed project be discussed with the County Engineer's Office at the earliest practical time in the planning stage.

Drainage systems which discharge directly into regulated drains, or involve construction within the statutory right-of-way for said drains, shall be subject to the approval of the Delaware County Drainage Board. Additionally, any drainage system which is intended to be dedicated as a regulated drain for public use shall be subject to the approval of the Delaware County Drainage Board.

Drainage systems may also be subject to the approval of the Indiana Department of Natural Resources and any construction within a Floodway shall have received a Certificate of Approval for Construction in a Floodway from the Natural Resources Commission.

Proposed construction within or an outfall into Indiana State Highway right-of-way shall have received the approval of and a permit granted by the Indiana Department of Transportation.

## 2. DEFINITIONS

For the purpose of these General Drainage Standards, the following definitions shall apply:

a. BOARD - The Drainage Board of Delaware County, Indiana, and any subordinate employee or advisor to whom they shall specifically delegate a responsibility authorized by these standards and regulations.

b. CAPACITY OF A STORM DRAIN FACILITY - The maximum flow that can be conveyed or stored by a storm drainage facility without causing damage to public or private property.

c. CHANNEL - A natural or artificial watercourse of perceptible extent which periodically or continuously contains moving water, or which forms a connecting link between two bodies of water. It has a defined bed and banks which serve to contain the water.

d. CONTIGUOUS - Adjoining or in actual contact with.

e. COUNTY - Delaware County, Indiana.

f. CULVERT - A closed conduit used for the passage of surface drainage water under a roadway, railroad, canal, or other impediment.

g. DETENTION BASIN - A facility constructed or modified to restrict the flow of storm water to a prescribed maximum rate, and to concurrently detain the excess waters that accumulate behind the outlet.



h. DETENTION STORAGE - The temporary detaining or storage of storm water in storage basins, on rooftops, in streets, parking lots, school yards, parks, open spaces, or other areas under predetermined and controlled conditions, with the release of drainage therefrom restricted by appropriately installed devices based upon a predetermined release rate.

i. DRAINAGE AREA - The area from which water is carried off by a drainage system, watershed or catchment area.

j. DRAINAGE BOARD - The Delaware County Drainage Board; see Board.

k. DRAINAGE FACILITIES - As used herein, drainage facilities shall mean all ditches, channels, conduits, retention-detention systems, tiles, swales, sewers, and other natural or artificial means of draining storm water from land.

l. DROP MANHOLE - Manhole having a vertical drop pipe connecting the inlet pipe to the outlet pipe. The vertical drop pipe shall be located immediately outside the manhole.

m. DRY BOTTOM DETENTION BASIN - A basin designed to be completely de-watered after having provided its planned detention of runoff during a storm event.

n. DURATION - The time period of a rainfall event.

o. ENGINEER, COUNTY - The County Engineer of Delaware County, Indiana.

p. EROSION - Wearing away of the land by running water and waves, abrasion and transportation.

q. FLOOD OR 100-YEAR FLOOD - That flood having a peak discharge which can be equalled or exceeded on the average of once in a one hundred (100) year period, as calculated by a method and procedure which is acceptable to and approved by the Indiana Natural Resources Commission.

r. FLOOD ELEVATION - The elevation at all locations delineating the maximum level of high waters for a flood of a given return period.

s. FLOOD HAZARD AREA - Those floodplains which have not been adequately protected from flooding caused by the 100-year flood, and are shown on the Delaware County Zone Maps or on the Flood Hazard or Floodway-Flood Boundary Maps incorporated as a part of the Flood Plain Management Ordinance of Delaware County, Indiana, or on maps provided by the Indiana Natural Resources Commission.

t. FLOOD PLAIN - The area adjoining a waterway which has been or may hereafter be covered by flood water from the 100-year

flood consisting of the floodway and the floodway fringe.

u. FLOOD PROTECTION GRADE - The elevation of the lowest floor of a building, including the basement, which shall be two feet above the elevation of the 100-year flood.

v. FLOODWAY - A portion of the flood plain consisting of the channel of a waterway plus any adjacent area that must be kept free from encroachment to maintain the carrying capacity of the waterway and decrease flood heights. The width of the floodway is determined by the U. S. Corps of Army Engineers and is delineated on the Floodway and Flood Boundary Maps for Delaware County, Indiana.

w. FLOODWAY FRINGE - That portion of the flood plain lying outside of the floodway which is inundated by the 100-year flood.

x. FOOTING DRAIN - A drain pipe installed around the exterior of a basement wall foundation to relieve water pressure caused by high groundwater elevation.

y. GRADE - The inclination or slope of a channel, canal, conduit, etc., or natural ground surface usually expressed in terms of the percentage the vertical rise (or fall) bears to the corresponding horizontal distance.

z. IMPERVIOUS - A term applied to material through which water cannot pass, or through which water passes with difficulty.

aa. INLET - An opening into a storm sewer system for the entrance of surface storm water runoff, more completely described as a storm sewer inlet.

bb. JUNCTION CHAMBER - A converging section of conduit, usually large enough for a man to enter, used to facilitate the flow from one or more conduits into a main conduit.

cc. LATERAL STORM SEWER - A sewer that has inlets connected to it but has no other storm sewer connected.

dd. MANHOLE - A storm sewer structure through which a man may enter to gain access to an underground storm sewer or enclosed structure.

ee. OFF-SITE - Everything not on site.

ff. ON-SITE - Located within the controlled area where runoff originates.

gg. OUTFALL - The point or location where storm runoff discharges from a sewer or drain. Also applies to the outfall sewer or channel which carries the storm runoff to the point of outfall.



hh. PEAK FLOW - The maximum rate of flow of water at a given point in a channel or conduit resulting from a predetermined storm or flood.

ii. RAINFALL INTENSITY - The cumulative depth of rainfall occurring over a given duration, normally expressed in inches per hour.

jj. REACH - Any length of river, channel or storm sewer.

kk. REGULATED AREA - All of unincorporated Delaware County, Indiana and any additional area for which an existing or proposed storm water drainage system impacts or will impact a watercourse maintained by Delaware County, Indiana.

ll. REGULATED DRAIN - An open or tiled ditch, as defined by law, which is subject to the jurisdiction and control of the Drainage Board of Delaware County, Indiana.

mm. RELEASE RATE - The amount of storm water released from a storm water control facility per unit of time.

nn. RETURN PERIOD - The average interval of time within which a given rainfall event will be equalled or exceeded once.

oo. RUNOFF COEFFICIENT - A decimal fraction relating the amount of rain which appears as runoff and reaches the storm sewer system to the total amount of rain falling.

pp. SEDIMENT - Material of soil and rock origin transported, carried or deposited by water.

qq. SIPHON - A closed conduit or portion of which lies above the hydraulic grade line, resulting in a pressure less than atmospheric and requiring a vacuum within the conduit to start flow.

rr. SPILLWAY - A waterway in or above a hydraulic structure, for the escape of excess water.

ss. STILLING BASIN - A basin used to slow water down or dissipate its energy.

tt. STORAGE DURATION - The length of time that water may be stored in any storm water control facility, computed from the time water first begins to be stored.

uu. STORM SEWER - A closed conduit for conveying collected storm water.

vv. STORM WATER RUNOFF - The water derived from rains falling within a tributary basin, flowing over the surface of the ground or collected in channels or conduits.

ww. SUBDIVISION - The division or partition of land as defined

by the Subdivision Ordinance of Delaware County, Indiana.

xx. TRIBUTARY - Contributing storm water from upstream land areas.

yy. WATERCOURSE - Any river, stream, creek, brook, branch, natural or man-made drainageway in or into which storm water runoff or floodwaters flow either regularly or intermittently.

zz. WATERSHED - A geographic area that drains surface water to a primary, common drainage facility.

aaa. WET BOTTOM DETENTION BASIN - A basin designed to retain a permanent pool of water after having provided its planned detention of runoff during a storm event.

### 3. DETERMINATION OF RUNOFF CHARACTERISTICS

Runoff characteristics may be computed using the Rational Method, the Soil Conservation Service (SCS) Method, hydrograph techniques and/or acceptable computer modelling. The computerized version of the SCS Method, known as the TR 55 software, is acceptable, and recommended. The Rational Method and the SCS Method are presented herein and certain tables, figures and forms have been provided relating to these methods.

a. THE RATIONAL METHOD - This method is based on the idea that the peak rate of surface outflow from a given watershed will be proportional to the watershed area and the average rainfall intensity over a period of time just sufficient for all parts of the watershed to contribute to the outflow. This proportionality is written in the following Rational Method formula:

$$Q = CiA$$

where Q = peak discharge (runoff) in cubic feet per second (cfs)  
C = ratio of peak runoff rate to average rainfall rate over the watershed during the time of concentration ( $t_c$ ) and is known as the runoff coefficient  
i = rainfall intensity in inches per hour  
A = contributing area of watershed/drainage basin under consideration in acres

The runoff coefficient (C) represents the characteristics of the drainage area. Where more than one runoff coefficient is applicable, a weighted average (composite C) shall be used as follows:

$$C_{comp} = \frac{(C_1A_1 + C_2A_2 + \dots + C_nA_n)}{A_t}$$

where  $C_1, C_2 \dots C_n$  are the individual runoff coefficients associated with component areas  $A_1, A_2 \dots A_n$ ; and  $A_t$  is the sum of  $A_1, A_2 \dots A_n$  (total drainage area in acres).



Table 1 provides runoff coefficients for different types of surfaces. Table 2 provides runoff coefficients and inlet times for different land uses. Sound engineering judgment must be used in choosing the runoff coefficient. The choice should reflect the consideration of such factors as interception, infiltration, surface detention, evaporation, transpiration, and antecedent moisture conditions as they exist on the designated site. In the instance of undeveloped land situated in an upstream area, a coefficient(s) shall be used which is related to the use or uses which are existing.

The intensity of rainfall ( $i$ ) is selected for a duration equal to the time of concentration ( $t_c$ ) for the drainage area. Rainfall intensity may be determined from the rainfall frequency curves shown in Figure 1 or from the data presented in Table 14.

The time of concentration ( $t_c$ ) is the travel time for the most hydraulically distant point to contribute to the point of discharge or outflow. The travel time to a given location is the sum of the overland flow time and the gutter flow time and the sewer flow time. Where the area under consideration includes sewer and overland flow, it must be divided into sub-basins since each type of travel time is calculated differently and the total time for all sub-basins would be the time of concentration ( $t_c$ ) to be used for design purposes. Tables 3(a, b, & c) contains various formulas for the calculation of overland flow time which is sheet flow across lawns, graded areas, fields, etc. The time of flow in the conduits may be estimated by the distance in feet divided by velocity of flow in feet per second. The velocity shall be determined by the Manning Formula. Inlet time is the combined time required for the runoff to reach the inlet of the storm sewer and includes overland flow time and flow time through established surface drainage channels such as swales, ditches and street gutters. (The graph in Figure 3 was developed by the SCS to show average velocities for estimating travel times.) For sewer design, the inlet time for each sub-basin must be compared to the travel time from all upstream sub-basins and the longer time selected.

In general, the Rational Method may be applied to small well-defined drainage basins as found in urban areas. The following list covers the basic assumptions used in the application of the Rational Method:

- The return period of the peak discharge is the same as that of the rainfall intensity.
- The rainfall is uniform in space over the watershed under consideration.
- The storm duration associated with the peak discharge is equal to the time of concentration for the drainage area.
- The runoff coefficient may depend on the return period,

consequently, the following conversions are used:

Return Period	Multiply C by
2 - 10 yr	1.0
25 yr	1.1
50 yr	1.2
100 yr	1.25

- The runoff coefficient is independent of the storm duration for a given watershed and reflects any changes in infiltration rates, soil types, and antecedent moisture conditions.

b. THE SOIL CONSERVATION SERVICE METHOD - The Soil Conservation Service Curve Number (CN) Method was developed to determine the quantity of runoff from a given amount of precipitation. The CN Method uses basin soil and cover types and the rainfall depth and antecedent moisture condition to predict the runoff volume. This method is recommended and is applicable for both rural and urban watersheds. If the soil type of the basin (drainage area in question) varies, the basin should be broken down into sub-basins of similar character or a composite CN calculated as follows:

$$CN_{comp} = \frac{(CN_1 A_1 + CN_2 A_2 + \dots + CN_n A_n)}{A_t}$$

Where  $CN_1, CN_2 \dots CN_n$  are the curve numbers associated with component areas  $A_1, A_2 \dots A_n$ , and  $A_t$  is the total acreage which is the sum of  $A_1 + A_2 + \dots + A_n$ .

The basic idea behind the Curve Number Method can be described in conjunction with Figure 2 which is a graph of quantity versus time. The upper line represents the total (accumulated) rainfall,  $P(t)$ , as a function of time. The dashed line represents the total abstraction or loss,  $L(t)$ , over time. The total abstraction is the sum of the initial abstraction,  $I_a$ , which is mainly due to surface wetting and depression storage, and the total infiltration,  $F(t)$ . It is assumed that no runoff occurs until  $I_a$  has been satisfied and that after a sufficiently long time,  $F(t)$  reaches a constant saturation value denoted by  $S - I_a$ . The symbol  $S$  stands for the ultimate total abstraction or, in other words, there is a point where the ground is totally saturated and all rainfall exceeding that point is runoff.  $S$  depends on soil type, cover and antecedent moisture condition. Soil type and cover is a function of the curve number which can be determined using Tables 6, 7, 8 and 9. The basic soil characteristics are presented in Table 4. The curve numbers presented in Tables 7, 8 and 9 are based on an Antecedent Moisture Condition II (AMCII) which is also known as the antecedent runoff condition (ARC). The Soil Conservation Service had previously used a system where the AMC was selected based on the criteria shown in Table 5. The TR 55 program uses the AMCII /ARC criteria.

The relationship between  $S$  and  $CN$  is as follows:



$$S = \frac{1000}{CN} - 10$$

The cumulative runoff,  $R(t)$ , is the difference between the total rainfall and the total abstraction. Also, the curve number method is based on the assumption that the ratio of runoff to water-available-for-runoff equals the ratio of infiltration to ultimate total abstraction. Finally, analysis of extensive data on rainfall and runoff provides the following relationship between  $I_a$  and  $S$ :

$$I_a = 0.2 \times S$$

Utilizing the basic assumptions and relationship, the following formula has been developed to determine cumulative runoff,  $R(t)$ , under the Curve Number Method:

$$R(t) = \frac{(P(t) - 0.2S)^2}{P(t) + 0.8S}$$

If  $P(t) \leq 0.2S$ , then  $R(t) = 0$ , since this means the total rainfall is less than or equal to the initial abstraction (surface wetting and depression storage) and there is no excess rainfall to become runoff.

Figure 2a provides a graphical solution for cumulative runoff ( $R(t)$ ) using  $Q$  to represent cumulative runoff rather than  $R(t)$ .

#### 4. DETERMINATION OF REQUIRED STORAGE VOLUMES

With urbanization, ground which once allowed infiltration of rainwater is covered with impervious parking lots, streets and homes, causing a higher percentage of rain to become surface runoff. Improvements associated with urbanization, such as streets, curbs and storm sewers, collect and convey surface runoff more rapidly than in an undeveloped situation which results in a higher runoff volume in a shorter period of time. To avoid overloading the larger drainage system, storage facilities shall be required to receive runoff generated by a developed site with a reduced release rate.

Undeveloped runoff characteristics shall be computed for the area of the parcel under consideration plus the area of the watershed flowing into the parcel. The permitted rate of discharge (outflow) for a developed condition shall not exceed the existing undeveloped 5-year runoff from the site, or the capacity of the receiving drainage facilities as determined by the entity having jurisdiction over such drainage facilities which could result in a more restrictive release rate than that calculated for the existing undeveloped 5-year runoff. Developed runoff characteristics (inflow) shall be computed for the parcel based upon a 50 year rainfall. The maximum difference between the inflow and outflow volumes, over various time intervals, is

the required storage. An allowance, equivalent to the reduction in flow rate provided, shall be made for upstream detention when such detention and release rate have previously been approved and constructed in accordance with the Delaware County Storm Drainage and Sediment Control Ordinance and these standards.

a. THE RATIONAL METHOD - The calculation of a peak runoff rate discussed in Section 3 can be extended to compute storage volumes by multiplying the peak flow rate by the storm duration. The peak outflow rate leaving the detention pond,  $O(t)$ , is calculated using the contributing undeveloped area,  $A_u$ , the undeveloped runoff coefficient,  $C_u$ , and the rainfall intensity,  $i_u$ , for the time of concentration of the undeveloped basin and the 5-year return period. The undeveloped runoff coefficient,  $C_u$ , shall not exceed .20 when using the Rational Method. This outflow rate is constant for all storm durations. The inflow rate,  $I(t)$ , is calculated using the contributing developed area,  $A_D$ , the developed runoff coefficient,  $C_D$ , and a rainfall intensity,  $i_D$ , corresponding to the various storm durations,  $t_d$ , for the 50 year return period. The maximum difference between the inflow and the outflow is the required storage. The blank form contained in Figure 4 is provided for the storage calculations under the Rational Method. The following is an example of such calculation adapted from the HERPIC County Storm Drainage Manual:

#### EXAMPLE - RATIONAL METHOD CALCULATION OF STORAGE

A 100 acre parcel of land which is currently a flat pasture with a clay and silt loam soil is to be developed with the following characteristics: 20% parks, 50% single family homes, and 30% business. The overland travel path has a length of 700 feet and a slope of 0.03 ft/ft. Determine the size of the detention pond required so that the 50 year runoff from the developed land will not exceed the 5 year runoff of the undeveloped land. First calculate the undeveloped runoff which will be the outflow rate,  $O$ , which equals  $Q$  in the formula  $Q = CiA$ . Since this is a calculation of the undeveloped runoff the formula is:

$$O = C_u i_u A_u, \text{ where}$$

$$A_u = 100 \text{ acres;}$$

$$C = .30 \text{ from Table 1 - Rural Runoff Coefficients, however, these standards require that the undeveloped runoff coefficient, } C_u, \text{ be less than or equal to .20, so}$$

$$C_u = .20;$$

$$i = \text{the 5 year return period intensity for the time of concentration, } t_c, \text{ for the 100 acre drainage basin which is calculated below using Kerby's formula from Table 3:}$$

$$t_c = 0.827 \times \frac{[0.40 \times 700]^{0.467}}{[0.03^{1/2}]} = 26.07 \text{ min.}$$

Using Figure 1, the intensity for a 5 year return period and a 26.07 minute duration is 2.80, so

$$i_u = 2.80; \text{ and, by inserting the appropriate values,}$$



$$O = (.20)(2.80)(100) = 56 \text{ cfs}$$

Second, calculate the developed runoff coefficient which will be a composite coefficient using an average of the coefficients set forth in Table 1 - Urban Runoff Coefficients:

$$C_{comp} = \frac{(.17 \times 20) + (.40 \times 50) + (.60 \times 30)}{100} = .41$$

$$C_D = .41$$

The inflow rate, I, is then calculated for various storm durations,  $t_d$ , where  $I = C_D i_D A_D$ . Using Figure 1 and Table 14, the rainfall intensities are found for the 50 year return period at durations of 10, 20, 30, 40, and 50 minutes and 1, 1.5, 2, 3, 4, 5, 6, 7, 8, 9, and 10 hours. Then the outflow is subtracted from the inflow and converted to acre/ft. The greatest difference is the required storage. The following chart shows the calculations.

Design Return Period = 50 yr      Release Rate Return Period = 5 yr  
 Watershed/Drainage Basin = 100 acres  
 Time of Concentration ( $t_c$ ) for the undeveloped basin = 26.07 min.  
 Undeveloped Rainfall Intensity = 2.80 inches/hour  
 Undeveloped Runoff Coefficient ( $C_u$ ) = .20  
 Undeveloped Runoff Rate ( $O = C_u i_u A_u$ ) = 56 cubic feet/second (cfs)  
 Developed Runoff Coefficient = .41

Storm Duration	Rainfall Intensity	Inflow Rate	Outflow Rate	Storage Rate	Required Storage
$t_d$	$i_D$	$I(t_d)$	O	$I(t_d) - O$	$[I(t_d) - O] \frac{t_d}{12}$
hours	inches/hr	( $C_D i_D A_D$ ) cfs	( $C_u i_u A_u$ ) cfs	cfs	acre/ft
.17	6.60	270.60	56.00	214.60	3.05
.33	4.75	194.75	56.00	138.75	3.82
.50	3.78	154.98	56.00	98.98	4.13
.67	3.30	135.30	56.00	79.30	4.42**
.83	2.75	112.75	56.00	56.75	3.93
1.00	2.38	97.58	56.00	41.58	3.46
1.50	1.85	75.85	56.00	19.85	2.48
2.00	1.46	59.86	56.00	3.86	.64
3.00	1.05	43.05	56.00	*	*
4.00	.86	35.26	56.00	*	*
5.00	.72	29.52	56.00	*	*
6.00	.63	25.83	56.00	*	*
7.00	.57	23.37	56.00	*	*
8.00	.50	20.50	56.00	*	*
9.00	.46	18.86	56.00	*	*
10.00	.42	17.22	56.00	*	*

\* Where inflow is less than the permitted outflow, no storage is required unless receiving system has capacity problems  
 \*\* Being the greatest amount, this is the required design storage

b. THE SOIL CONSERVATION SERVICE CURVE NUMBER METHOD - As shown in Section 3, the direct surface runoff,  $R(t)$ , from a given amount of precipitation is predicted as a function of soil type, land use and antecedent moisture condition (or antecedent runoff condition). The TR 55 software may be used to compute required storage volumes or a procedure similar to the Rational Method in Section 4a may be used once the cumulative precipitation,  $P$ , and the direct runoff,  $R$ , is calculated for each specified storm duration,  $t_d$ . Multiplying  $R(t_d)$  by the watershed/basin area and converting to cubic feet gives a volume of runoff. The undeveloped runoff is subtracted and a storage volume is found for that duration, with the largest being the required volume. This method assumes that all of the runoff reaches the storage facility during the storm duration. The permitted outflow may be found by using the Rational Method ( $Q=Cu i u A_u$ ) or by using a specified value obtained through hydrographs. Figure 5 provides a blank form for calculating storage using the SCS Curve Number Method. The following example is provided using the same information as used in the Rational Method example.

EXAMPLE - SCS CURVE NUMBER METHOD CALCULATION OF STORAGE

The permitted outflow shall be that calculated under the Rational Method -  $Q = 56$  cfs.

The rainfall intensity,  $i$ , shall be for the 50 yr return period indicated as 150.

A composite curve number must be calculated for the developed site using Table 9 for soil type C (clay & silt loam) and 1/3 acre lots for the single family homes where the development will consist of 20% parks, 50% single family, and 30% business.

CN for parks = 74; CN for homes = 81; CN for business = 94

$$CN_{comp} = \frac{(74 \times 20) + (81 \times 50) + (94 \times 30)}{100} = 83.5 \text{ (AMCII)}$$

$$S = \frac{1000}{83.5} - 10 = 1.98$$

The inflow volume in inches,  $R(t_d)$ , must be calculated for each duration using the following formula:

$$R(t_d) = \frac{[P(t_d) - 0.2S]^2}{P(t_d) + 0.8S} = \frac{[P(t_d) - 0.2 \times 1.98]^2}{P(t_d) + 0.8 \times 1.98}$$

The outflow,  $Q$ , shall be calculated using 56 cfs times the various storm durations indicated as  $Q t_d$ .

The storage volumes,  $s(t_d)$ , shall be calculated by subtracting the inflow from the outflow and multiplying by the factor 1/12 to convert from cfs/hour to acre/feet.



Design Return Period = 50 yr      Release Rate Return Period = 5 yr  
 Watershed/Basin Area = 100 acres  
 Undeveloped Runoff Rate (O) = 56 cfs  
 Developed Curve Number = 83.5  
 Ultimate Abstraction S = 1.98

Storm Duration	Rainfall Intensity	Rainfall Amount	Cumulative Runoff	Inflow Volume	Outflow Volume	Required Storage
$t_d$	$i_{50}$	$P(t_d)$	$R(t_d)$	$R(t_d)A_d$	$O t_d$	$[R(t_d)A_d - O t_d] \times 1/12$
hours	in/hr	in	in	in/acre	cfs/hr	acre/ft
.17	6.60	1.12	.19	19.00	9.52	.79
.33	4.75	1.57	.44	44.00	18.48	2.13
.50	3.78	1.89	.64	64.00	28.00	3.00
.67	3.30	2.21	.87	87.00	37.52	4.12**
.83	2.75	2.28	.92	92.00	46.48	3.79
1.00	2.38	2.38	.99	99.00	56.00	3.58
1.50	1.85	2.78	1.30	130.00	84.00	3.83
2.00	1.46	2.92	1.41	141.00	112.00	2.42
3.00	1.05	3.15	1.60	160.00	168.00	*
4.00	.86	3.44	1.84	184.00	224.00	*
5.00	.72	3.60	1.98	198.00	280.00	*
6.00	.63	3.78	2.13	213.00	336.00	*
7.00	.57	3.99	2.31	231.00	392.00	*
8.00	.50	4.00	2.32	232.00	448.00	*
9.00	.46	4.14	2.45	245.00	504.00	*
10.00	.42	4.20	2.50	250.00	560.00	*

\* Since outflow is greater than inflow, no storage is needed

\*\* Being the greatest amount, this is the required design storage

## 5. DESIGN OF STORAGE FACILITIES

Storage facilities can be divided into two basic categories: detention and retention. Detention is the temporary storage of the runoff in excess of that released and the facilities can be designed as dry bottom or wet bottom basins. Normally, some time after the storm, the facility is emptied and resumes its normal function. Detention facilities may be designed for multi-purposes if approved by the County Engineer. Parking lots, rooftops, and parks are common detention facilities for temporary storage. Ponds which have restricted outlets are also detention facilities. Retention facilities retain runoff for an indefinite amount of time. Ponds and lakes are examples of retention facilities. Retention ponds should have both an aesthetic use and a practical use. Prior to installation of a retention pond, the developer should consider potential water quality problems associated with low flow in dry weather, direct pollution from surface runoff and/or high nutrient levels which may cause algae

growth. If these are potential problems, a detention pond should be considered. For a wet bottom basin to be a detention pond, it must have a restricted outlet. Where favorable soil conditions exist, runoff may be allowed to seep into the soil using infiltration basins or ditches. Certain design requirements may be made by the County Engineer based on the individual site for the storage facility.

a. GENERAL DESIGN GUIDELINES FOR STORAGE FACILITIES -

- All storage facilities, excluding parking lots and rooftops, shall be separated by not less than fifty (50) feet from any building or structure to be occupied.
- Screens or bars shall be placed over all inlets and outlets greater than six (6) inches for safety and to collect debris.
- Outlet control structures shall be designed to operate as simply as possible and shall require little or no maintenance and/or attention for proper operation.
- An emergency overland overflow facility, such as but not limited to a spillway or weir, shall be installed to handle flows exceeding the design capacity to try to prevent damage to surrounding property. The overflow facility shall be designed so that its operation is automatic and does not require manual attention.
- Outlets which discharge overland shall be provided with protection to prohibit erosion. Runoff and erosion control systems shall be installed as soon as possible during the course of site development.
- Debris and trash removal and other necessary maintenance shall be performed on a regular basis to assure continued operation in conformance with design.

b. DESIGN GUIDELINES FOR WET BOTTOM BASINS -

- When possible, permanent ponds should be stocked with fish. To provide a habitat suitable for aquatic life, the pond should have a surface area of at least 1/2 acre and a minimum depth of at least 10 feet over at least 25% of the total area. The average depth of the remaining area should be at least 5 feet. This will inhibit insect breeding and weed growth although maintenance may still be necessary.
- A controlled positive outlet will be required to maintain the design water level and provide required detention storage above the design water level. A means of maintaining the design water level during prolonged periods of dry weather is required.
- Wet bottom basins can be developed to provide a wetland environment. Every effort should be made to aesthetically integrate the facility with the surrounding area.



- To maximize water quality, inlets and outlets should be located on opposite ends of the basin to provide for maximum settling.
- A minimum side slope of 3:1 is required and a four (4) to six (6) foot safety ledge shall be installed. In excavated basins, the underwater side slopes shall be stable.
- Periodic maintenance is required to control weed and larval growth. The basin shall be designed to provide for the easy removal of sediment which will accumulate during periods of operation, consequently, basins should be designed to collect sediment and debris in specific locations so that removal costs are kept to a minimum.
- Basins shall be designed with an additional six percent (6%) of available capacity to allow for sediment accumulation and to permit the basin to function for reasonable periods of time between cleanings.

c. DESIGN GUIDELINES FOR DRY BOTTOM BASINS -

- Where the basin is intended to be multi-purpose, an underdrain system shall be constructed to minimize the wetness of the pond bottom (creating a dry bottom pond). The underdrain may discharge directly to the receiving facility. Alternatives to the underdrain include the provisions of natural grades to outlet structures and longitudinal and transverse grades to perimeter drainage facilities and paved gutters.
- The pond bottom and side slopes should be finished with at least four inches of topsoil and seeded or sodded to be capable of withstanding periodic inundation.
- The maximum volume of water stored and subsequently released at the design release rate shall not result in a storage duration in excess of 48 hours unless additional storms occur within that period.
- Every effort should be made to aesthetically integrate facilities with the surrounding area.

d. DESIGN GUIDELINES FOR OTHER TYPES OF STORAGE FACILITIES -

PARKING LOTS - Parking lots may be utilized for temporary storage of runoff in either depressed areas where the runoff accumulates and is released through a drain using restrictors (small diameter pipes, orifices, or small grates) or by utilizing paved surface to convey runoff to grassed areas or seepage pits adjacent to the lot. The following guidelines are for depression storage:

- The storage areas of the parking lots should be restricted to remote areas or those which cause the least inconvenience to users.

- The maximum depth of water should not exceed 6 inches.
- The parking lot should be drained in at least 30 minutes after rainfall termination.
- Frequent maintenance is necessary to ensure that drain openings do not plug up.
- Orifices less than 4 inches are not permitted due to clogging.

ROOFTOP STORAGE - Detention requirements may be met in total or in part by the temporary storage of rainfall on rooftops. Most building codes for this area require that rooftops withstand live loadings of 30 to 40 pounds per square foot which is equivalent to about 6 inches of water (usually much greater than that required for normal detention on flat roofs). Problems associated with rooftop storage are leakage, overflows and structural damage. To minimize problems, the following standards are required:

- Provide extra membrane liners to create a watertight seal on the roof.
- Place overflow drains at the design depth to reduce damage due to clogging of drains.
- Design the roof to structurally withstand a live load of at least 35 pounds per square foot.
- Design the roof so that the maximum depth with a flat roof is 3 inches and with a sloped roof is 6 inches and space each drain to handle 10,000 square feet of roof area.
- Determine the allowable outflow rate from the rooftop and then use the chart below to size the leader (pipe which takes the water from the roof vertically to storm drain) or the horizontal piping to release the water:

#### SYSTEM SIZING DATA

Pipe Diameter in inches	Roof Drains and Vertical Leaders (gpm)	Horizontal Storm Drainage Piping Slope in inches per foot		
		1/8	1/4	1/2
Flow Capacity in gallons per minute (gpm)				
2	30	-	-	-
2.5	54	-	-	-
3	92	34	48	69
4	192	78	110	157
5	360	139	197	278
6	563	223	315	446
8	1208	479	679	958
10	-	863	1217	1725
12	-	1388	1958	2775
15	-	2479	3500	4958



INFILTRATION SYSTEMS - The temporary storage and subsequent infiltration of stormwater into the soil may be accomplished through the use of a basin, trench or porous asphalt (which is a special type of pavement known as open graded permeable material (OGPM) with a gravel subbase and its use is subject to approval of the County Engineer). These methods are used when the receiving stream cannot accept any additional runoff, where it is necessary to recharge the groundwater (not a typical problem in this area) or where a positive gravity outlet is not feasible. The rate at which the water can percolate through the soil depends upon the soil makeup and the water table location. The following guidelines apply to stormwater infiltration systems (seepage pits, etc.):

- Soil permeability is a measure of the ability of the soil to allow infiltration. Typical values of the coefficient of permeability, denoted by K, are as follows:

Typical Soil	Permeability K (ft/sec)	Relative Permeability
Coarse, Gravel	over $5.0 \times 10^{-1}$	Very Permeable
Sand, Fine Sand	$5.0 \times 10^{-1}$ to $5.0 \times 10^{-3}$	Medium Permeability
Silty Sand, Dirty Sand	$5.0 \times 10^{-3}$ to $5.0 \times 10^{-5}$	Low Permeability
Silt	$5.0 \times 10^{-5}$ to $5.0 \times 10^{-7}$	Very Low Permeability
Clay	less than $5.0 \times 10^{-7}$	Practically Impervious

These values can be used with the following equation, known as Darcy's Law, to determine the required size of the trench or basin and is applicable for a fully saturated soil.

$$Q = AKi$$

where, Q = flow rate (cfs)  
 A = cross-sectional area of soil through which the water flows (ft<sup>2</sup>)  
 K = coefficient of permeability (ft/sec)  
 i = headloss or the gradient over a flow distance L (it is recommended that a factor of safety of 2 be used, i.e. divide Q in half) (ft/ft)

Figure 6 shows a typical recharge trench used for infiltration. The void space in the rock fill of a trench or basin must have a sufficient capacity to detain the difference between the incoming runoff, the water which is infiltrating during the entire storm, and the amount which may be released. The

procedure for determining the storage requirement is as follows:

- Calculate the volume of accumulated runoff for the 50 year return period using the Rational Method, SCS Method, or hydrographs.
- Calculate the allowable release volume based on the existing 5 year runoff which does not have to be infiltrated.
- Calculate the volume of water flowing through the soil at time  $t$  using the Darcy's Law equation ( $Q=AKi$ ).
- The difference between the inflow volume and the allowable release rate and percolated volume is the required storage. The largest required storage when all durations are considered is the design requirement. Design the basin or trench to have a void volume equal to the maximum required storage.

Use of infiltration systems may not always be feasible in certain locations due to soil types with very low to no permeability.

e. OUTFLOW CONTROL DEVICES - Figure 6a shows 2 of the 3 most common outflow control devices which will regulate the flowrate - the orifice, the weir and pipe. An orifice is a circular or rectangular opening of a prescribed shape and perimeter through which the water flows. The flowrate depends upon the height of the water above the opening and the type of orifice. A weir is a depression or cutout in a wall or channel through which water flows which is often used for control of overflows. Pipe is self-explanatory and Manning's Equation is used to determine flowrates, factoring in different variables depending on the specific circumstances. Usually flowrates will be known and where the flowrate may require a size of pipe not commercially available, the County Engineer shall determine the required size.

## 6. DESIGN REQUIREMENTS FOR VARIOUS PARTS OF A DRAINAGE FACILITY

### a. GENERAL REQUIREMENTS -

- The minor drainage system such as inlets, manholes, street gutters, roadside ditches, swales, sewers and small channels which collect storm water runoff must accommodate peak runoff from a 10 year return period storm. Rainfall duration shall be equal to the time of concentration or one hour if the time of concentration is less than one hour.
- The major drainage system includes the watershed or portion thereof which will become operative once the capacity of the minor system is exceeded, such as open channels, natural watercourses, and storage facilities. Design and accommodation requirements of the major drainage system are set forth throughout these standards.
- Open channels carrying peak flows greater than 30 cubic feet per second shall be capable of accommodating peak runoff for a 50 year return period storm within the drainage easement.



- Culverts shall be capable of accommodating peak runoff from a 50 year return period storm when crossing under roads which are part of the functional classification system for Delaware County, Indiana, and are classified as principal arterials, minor arterials, or major collectors. Culverts crossing under minor collectors or local non-classified roads shall be capable of accommodating peak runoff from a 25 year return period storm. Regardless of this provision, no culvert shall be designed to carry less than the existing capacity of the channel.

- The spread, top width or encroachment of stormwater into a street shall be less than four (4) feet for streets without parking and a twelve (12) foot maximum encroachment or a maximum depth of 0.35 feet for a street with parking.

b. REQUIREMENTS FOR CLOSED CONDUIT/STORM SEWER SYSTEMS -

- Storm sewer systems shall be sized based upon the Manning Formula, expressed as follows:

$$V = (1.49/n) \times R^{2/3} \times S^{1/2}$$

where symbols in the formula have the following meaning:

R = hydraulic radius in feet  
V = mean velocity of flow in feet per second (fps)  
n = coefficient of roughness  
S = slope of energy gradient in feet per foot

and the hydraulic radius, R, is defined as the cross sectional area of flow divided by the wetted flow surface or wetted perimeter. Typical n values and maximum permissible velocities for storm sewer materials are listed in Table 10 and roughness coefficient, n, values for other materials are found in Table 11.

- The minimum size for storm sewer pipe shall be twelve (12) inches in diameter, however, the diameter of a single lead from a catch basin or inlet conveying small runoff rates may be 10 inches. Enlargement of the pipe size shall be made as is warranted by hydraulic gradient considerations. Detention metering pipes are not included under this requirement.

- Sewer grade shall be such that a minimum of three (3) feet of cover is maintained over the top of the pipe, however, cover depth may be less than the minimum upon approval of the County Engineer who may impose additional design requirements such as extra strength pipe or special trench backfill procedures. Uniform slopes shall be maintained between inlets, manholes and inlets to manholes. Final grade shall be set with full consideration of the capacity required, sedimentation problems and other design parameters.

- Minimum and maximum allowable slopes shall be those capable of producing velocities of two and one-half (2.5) and fifteen (15) feet per second, respectively, when the sewer is flowing

full.

- Head loss due to friction in open channels and pipes with uniform flow shall be determined by the formula:

$$S = \frac{n^2 \times V^2}{2.22 \times R^4/3}$$

where S = headloss in feet per linear foot of drain  
n = coefficient of roughness  
V = mean velocity of flow in feet per second  
R = hydraulic radius in feet

- Manholes shall be placed whenever there is a junction, a change in grade or a change in direction. A catch basin or inlet may be used instead of a manhole if it has sufficient size. The maximum spacing between manholes shall be 400 feet for smaller diameter pipe of 12 inches to 42 inches and 600 feet for larger diameter pipe of 48 inches and above.

- Inlets shall be placed at all low points in the grade of the gutter and at intersections to prevent the stormwater from flowing across traffic lanes and crosswalks. In addition, when the stormwater depth reaches a height greater than that of the curb or the width of flow extends too far in the street (see encroachment under General Requirements above), an inlet shall be placed to capture the flow.

- When the Delaware County Commissioners are to be responsible for maintenance, minimum easements shall be dedicated to the County as follows:

<u>Pipe Size</u>	<u>Minimum Easement Width</u>
12" - 24"	20 feet
>24"	30 feet

These easement requirements do not apply to any facility which shall become a part of the regulated drain system of Delaware County, Indiana. The easements for regulated drains shall be in accordance with statutory requirements and are subject to the approval of the Delaware County Drainage Board.

## 7. HYDRAULIC GRADIENTS

The hydraulic gradient is a line connecting points to which water will rise in manholes and inlets throughout the system during the design flow. The hydraulic gradient shall be determined starting at the downstream end of the proposed drainage system. Where a proposed drainage system is connected to an existing drainage system, the hydraulic gradient at the point of junction shall be determined from the hydraulic gradient computations of the existing drain. The design engineer shall determine the hydraulic gradient by



field-investigating the existing system. Where the proposed drainage system discharges into a stream, flow conditions of this stream shall be investigated. Where the tailwater elevation is higher than the proposed crown elevation, the hydraulic gradient shall begin at this tailwater elevation. Where free outfall conditions exist, the hydraulic gradient shall begin at the crown of the proposed drain or the critical flow depth in the outfall conduit. Next, the friction loss in the pipe and head loss in the structure shall be added. The hydraulic gradient to the upstream end of the proposed drainage system shall be determined by adding a series of friction losses in sections of drains and losses in structures (Table 13). For open road sections (shoulders and side ditches), the hydraulic gradient shall not be above the invert of the side ditch. Full consideration shall be given to possible future extensions of the systems.

In storm drain systems flowing full, all losses of energy through resistance of flow in pipes, by changes of momentum or by interference with flow patterns at junctions, must be accounted for by the accumulative head loss along the system from its initial upstream inlet to its outlet. The purpose of accurate determinations of head losses at junctions is to include these values in a progressive calculation of the hydraulic gradient along the storm drain system. In this way, it is possible to determine the water surface elevation which will exist at each structure.

Delaware County does not require the hydraulic grade line to be established for all storm drainage design. It is not necessary to compute the hydraulic grade line of a conduit run if the slope and the pipe sizes are chosen so that the slope is equal to or greater than friction slope, the inside top surfaces rather than the flow lines of successive pipes are lined up at changes in size, and the surface of the water at the point of discharge will not rise above the top of the outlet. In such cases, the pipe will not operate under pressure and the slope of the water surface under capacity discharge will approximately parallel the slope of the invert of the pipe.

Lacking these conditions or when it is desired to check the system against a larger flood than that used in sizing the pipes, and if the tailwater is known, then the hydraulic grade line and energy line shall be computed and plotted. The friction head loss shall be determined by direct application of Mannings Equation or by appropriate nomographs. Minor losses due to turbulence at structures shall be determined as follows:

- The following total energy head losses at structures shall be determined for inlets, manholes, wye branches or bends in the design of closed conduits. Refer to Table 13 for details of each case. Minimum head loss used at any structure shall be 0.10 foot, unless otherwise approved.
- The basic equation for most cases, where there is both

upstream and downstream velocity, takes the form as set forth below with the various conditions of the coefficient  $K_j$ , shown on Table 13:

$$h_j = K_j \times \frac{V_2^2 - V_1^2}{2g}$$

$h_j$  = junction or structure head loss in feet

$V_1$  = velocity in upstream pipe in fps

$V_2$  = velocity in downstream pipe in fps

$K_j$  = junction or structure coefficient or loss

In the case where the initial velocity is negligible, the equation for head loss becomes:

$$h_g = K_j \times \frac{V_2^2}{2g}$$

Short radius bends may be used on 24 inch and larger pipes when flow must undergo a direction change at a junction or bend. Reductions in head loss at manholes may be realized in this way. A manhole shall always be located at the end of such short radius bends.

## 8. DESIGN REQUIREMENTS AND GUIDELINES FOR OPEN CHANNEL SYSTEMS

a. THE MANNING FORMULA - Waterway area for channels shall be determined based on the Manning Formula, expressed as follows:

$$Q = VA = (1.49/n) \times R^{2/3} \times S^{1/2} \times A$$

where symbols in the formula have the following meaning:

A = waterway area of the channel in square feet

V = velocity of flow in feet per second (fps)

R = hydraulic radius in feet

S = slope of energy gradient in foot per foot

Q = discharge in cubic feet per second (cfs)

n = roughness coefficient

b. CHANNEL CROSS SECTION AND GRADE - The required channel cross section and grade are determined by the design capacity, the material in which the channel is to be constructed and the



requirements for maintenance. A minimum depth may be required to provide adequate outlets for subsurface drains, tributary ditches, or streams and to deal with backwater curves which will result in subsequent back up in a tributary with a depth lower than the larger channel. The channel grade shall be such that the velocity in the channel is high enough to prevent siltation but low enough to prevent erosion. Velocities less than 1.5 feet per second should be avoided because siltation will take place and ultimately reduce the channel cross section. In general, a minimum mean velocity of 3 feet per second is desired when the percentage of silt is small. The maximum permissible velocities in vegetal lined channels are shown in Table 16. Developments through which the channel is to be constructed must be considered in design of the channel section.

c. SIDE SLOPES - For purposes of safety, construction, maintenance and erosion resistance, it is recommended that the channel side slopes be 3:1 or flatter. However, earthen channel side slopes shall be no steeper than 2:1 and, where channels will be lined, side slopes shall be no steeper than 1.5:1 with adequate provisions made for weep holes. Side slopes steeper than 1.5:1 may be used for lined channels provided that the side lining and structural retaining wall are designed and constructed with provisions for live and dead load surcharges.

d. CHANNEL STABILITY - Characteristics of a stable channel are:

- it neither aggrades nor degrades beyond tolerable limits;
- the channel banks do not erode to the extent that the channel cross section is changed appreciably;
- excessive sediment bars do not develop;
- excessive erosion does not occur around culverts, bridges, or elsewhere; and
- gullies do not form or enlarge due to entry of uncontrolled surface flow to the channel.

Channel stability shall be determined for an aged condition and the velocity shall be based on the design flow or the bank full flow, whichever is greater, using "n" values for various channel linings. Channel stability must be checked for conditions immediately after construction. For this stability analysis, the velocity shall be calculated for the expected flow from a 10 year return period or the bank full flow, whichever is smaller. The "n" value for newly constructed channels in fine grained soils and sands shall not exceed 0.025. The allowable velocity in the newly constructed channel may be increased by a maximum of 20% to reflect the effects of vegetation to be established under the following conditions:

- the soil and site in which the channel is to be constructed are suitable for rapid establishment and support of erosion controlling vegetation;
- species of erosion controlling vegetation adapted to the area and proven methods of establishment are shown; and
- the channel design includes detailed plans for establishment

of vegetation on the channel side slopes.

e. **ADDITIONAL DRAINAGE OF WATERWAYS** - Vegetated waterways that are subject to low flows of long duration or where wet conditions prevail shall be drained with a tile system or by other means such as paved gutters. Tile lines may be outletted through a drop structure at the end of the waterway or through a standard tile outlet.

f. **APPURTENANT STRUCTURES** - The design of channels will provide all structures required for the proper functioning of the channel and the laterals thereto and travelways for operation and maintenance. Recessed inlets and structures needed for entry of surface and subsurface flow into channels without significant erosion or degradation shall be included in the design of channel improvements. The design is also to provide the necessary flood gates, water level control devices and any other appurtenance affecting the functioning of th channel. The effect of channel improvements on existing culverts, bridges, buried cables, pipelines and inlet structures for surface and subsurface drainage on the channel being improved and laterals thereto shall be evaluated to determine the need for modification or replacement. Culverts and bridges which are modified or added as part of channel improvement projects shall meet reasonable standards for the type of structure and shall have a minimum capacity equal to the design discharge or an applicable governmental agency design requirement, whichever is greater.

g. **DISPOSITION OF SPOIL** - Spoil material resulting from clearing, grubbing and channel excavation shall be disposed in such a manner that will:

- minimize overbank wash;
- provide for the free flow of water between the channel and floodplain unless valley routing and water surface profiles are based on continuous dikes being installed;
- not hinder the development of travelways for maintenance;
- leave the right-of-way in the best condition feasible, consistent with the project purpose for productive use by the owner;
- improve the aesthetic appearance of the site to the extent feasible; and
- be approved by the Indiana Department of Natural Resources (IDNR) and/or the US Army Corps of Engineers (as applicable) if deposited in the floodway.

h. **MATERIALS AND CONSTRUCTION** - Materials acceptable for use as channel lining are:

- grass
- concrete, trowel finish
- concrete, broom or float finish
- guinite
- gabion
- rip rap placed



- rip rap dumped

Other lining materials shall receive specific approval from the County Engineer, or the County Surveyor or Drainage Board if involving a regulated drain.

The roughness coefficients of various channel materials are:

<u>Materials</u>	<u>Roughness Coefficient (n)</u>
Concrete, trowel finish	0.013
Concrete, broom or float finish	0.015
Guinite	0.018
New earth (uniform, sodded, clay)	0.025
Gabion	0.028
Rip Rap placed	0.030
Existing earth (uniform, with weeds)	0.030
Swale with grass	0.030
Rip Rap dumped	0.035
Dense growth of weeds	0.035
Dense weeds and brush	0.040

i. GENERAL REQUIREMENTS - Specifics on open channel design are to be found in the HERPIC County Storm Drainage Manual which is recommended for a more in-depth analysis. The following general requirements are applicable to open channel design in Delaware County, Indiana:

- Flow of an open channel into a closed system is prohibited, unless quantity and head loss computations demonstrate the closed conduit to be capable of carrying all of the open channel flow with no reduction in velocity.

- Water depths of greater than 3 feet should be given special attention.

- Freeboard is required for all channel design adequate to cope with hydraulic jumps and other factors such as wave action.

- Where Delaware County is responsible for the drainage system/ open channel, easements shall be provided in accordance with the statutory requirements for regulated drains, as approved by the Delaware County Drainage Board, or at a width of at least 25 feet from the top of the bank for non-regulated drains.

- Sound engineering principles are to be used to limit the maximum open channel velocity equal to or less than 6 feet per second. Those velocities in excess will be evaluated as they apply to the drainage proposal under review.

## 9. SPECIFICATIONS FOR EROSION CONTROL SYSTEMS

a. CONFORMANCE WITH STATE REQUIREMENTS - All land alterations involving five (5) or more acres shall be accomplished in full

compliance with the requirements of the Indiana Department of Environmental Management (IDEM), the Indiana Department of Natural Resources (IDNR) and the Delaware County Soil and Water Conservation District (DCSWD).

b. PROTECTION METHODS FOR VARIOUS PARTS OF A DRAINAGE SYSTEM - Erosion is likely to occur at any concentration of flow. The most common areas of flow concentration occur on the outer banks or curved channels, where a culvert outlet or inlet meets the borrow ditch, where the longitudinal slope of the ditch exceeds 2% depending on the soil types, and where there is sheet flow over a backslope.

Depending on the anticipated severity of erosion, three major types of control are to be utilized, either singly or in combination:

- Fertilized, seeded and mulched topsoil or sod.
- Stabilizing the seeded topsoil with excelsior or other fiber matting of varying strength.
- Permanent protection using one or more of the following:
  1. dumped rock or broken concrete riprap
  2. gabions (rock filled baskets)
  3. concrete or asphalt slope paving
  4. drop structures
  5. intercepting dikes

Figure 7 shows a convenient guide to the choice of method based on the depth of flow in, and slope of, the channel. Additional provisions for certain permanent protections are as follows:

- Dump-Stone Linings: The gradation of the material shall be such that no individual piece weighs more than 120 pounds; 90-100% of the material passes a 12 inch sieve; 20-60% of the material passes a 6 inch sieve; and not more than 10% of the material passes a 1.5 inch sieve. Grouted rip rap may be required by the County Engineer where slope conditions may warrant additional stability.
- Gabions: The placement and construction of gabions (rip rap enclosed in a wire mesh basket) is similar to that for dumped stone discussed above. The method of construction and placement and the selection of same size are defined in Reference No. 13, SCS Engineering Field Manual. Reference must be made to the manufacturer's literature to insure proper design of the gabion installation.
- Concrete Slope Paving: Figure 9 illustrates a typical cross section for concrete slope protection and should be used as a guide for design.

Figures 8 through 11 illustrate various methods of erosion control which are more fully described as follows:



- The filter blanket should consist of one or more layers of gravel, crushed stone or sand. The filter blanket is usually needed beneath the rip rap cover to prevent the water from removing bank material through the voids in the rip rap. Filter cloth can be used in lieu of a filter blanket.
- The upper vertical limit of protective cover should extend at least 1 foot above the design high water. This allowance for freeboard depends upon the velocities near the rip rap cover and, at some locations, upon the height of waves that might be generated on the water surface. Established sod above the stone protection will provide considerable protection from floods which overtop the rip rap cover.
- The purpose of the toe protection is to prevent undermining, not to support the blanket. Unless the protection has sufficient stability to support itself on the embankment slope, the protection cannot be considered adequate.
- The bank protection should extend both upstream and downstream from the points of reverse curvature on the outside of a curved channel.
- Bank protection is usually not required on the inside of a curve unless return of overbank flow creates a scour problem.
- On a straight channel, bank protection should begin and end at a stable feature in the bank. Where a stable feature does not exist, cutoffs should be provided as shown on Figure 10.
- Where the protective cover is long, intermediate cutoffs should be provided to reduce the hazard of complete failure of the stone blanket.

## 10. MISCELLANEOUS STANDARDS

a. CONSTRUCTION/MAINTENANCE/INSPECTIONS - The construction cost of storm water control systems and facilities as required by these standards shall be accepted as part of the cost of land development. Storm water control systems may be planned and constructed jointly by two or more developers as long as compliance with these standards and with the Storm Drainage and Sediment Control Ordinance is maintained. Maintenance of storm water storage facilities during construction and thereafter shall be the responsibility of the land developer/owner. Assignment of responsibility for maintaining facilities serving more than one lot or holding shall be documented by appropriate covenants to property deeds, unless responsibility is formally accepted by a public body, and shall be determined before the final drainage plans are approved. Also prior to approval of final drainage plans, any easements, land acquisitions, etc. necessary for off-site drainage shall be obtained. All public and privately owned storage facilities may be inspected by representatives of Delaware County during and after construction, covering physical

conditions, available storage capacity and operational condition of key facility elements. Any problems will be reported to the person or entity responsible for the facility. If deficiencies are found by the inspection, the owner of the facility will be required to take the necessary measures to correct such deficiencies. If the owner fails to do so, the County will undertake the work and collect from the owner using lien rights, if necessary.

b. AS-BUILT PLANS - After completion of a project and before final approval and acceptance can be made, a professionally prepared and certified "As-Built" set of plans shall be submitted to the County Engineer for review. These plans shall include all pertinent data relevant to the completed storm drainage system and shall include:

- pipe size and pipe material
- invert elevations
- top rim elevations
- lengths of all pipe structures
- data and calculations showing storage volumes
- a Certificate of Compliance

All such submitted plans shall be reviewed for compliance within 30 days after submission. If notice of non-compliance is not given within 30 days of submission, the plans shall be construed as approved and accepted.

c. MISCELLANEOUS STRUCTURES -

- SUMP PUMPS: Sump pumps installed to receive and discharge groundwaters or other storm waters shall be connected to the storm sewer where possible or discharged into a designated storm drainage channel. Sump pumps installed to receive and discharge floor drain flow or other sanitary sewage shall be connected to the sanitary sewer/facilities. A sump pump shall be used for one function only, either the discharge of storm waters or the discharge of sanitary sewage.

- DOWN SPOUTS: All down spouts or roof drains shall discharge onto the ground or be connected to the storm sewer. No down spouts or roof drains shall be connected to the sanitary sewers.

- FOOTING DRAIN: Footing drains shall be connected to storm sewers where possible or designated storm drainage channels. No footing drains or drainage tile shall be connected to the sanitary sewer.

- BASEMENT FLOOR DRAINS: Basement floor drains shall be connected to the sanitary sewer/facility.

- PERIMETER DRAINS: All perimeter underdrains required as a part of site development, such as for installation of a septic system, shall be connected to a storm sewer where possible or discharged into a designated storm drainage channel. No



perimeter drain shall be connected to any sanitary sewage facility.

#### 11. DISCLAIMER OF LIABILITY

The degree of protection required by these standards is considered reasonable for regulatory purposes and is based on historical records, engineering and scientific methods of study. Larger storms may occur or storm water runoff depths may be increased by man-made or natural causes. These standards do not imply that land uses permitted will be free from storm water damage. These standards shall not create liability on the part of Delaware County, Indiana or any officer or employee thereof for any damage which may result from reliance on these standards or on any administrative decision lawfully made thereunder.

#### 12. EXEMPTION FOR PRIOR PLANS

Any residential, commercial or industrial subdivision or construction project which has had its drainage plan approved by the County Engineer, or other entity with authority to approved such plans, prior to the effective date of these standards shall be exempt from the requirements contained herein. Any development for which a local building or improvement location permit has been issued prior to the effective date of these standards shall be exempt from the requirements contained herein.

#### 13. STANDARD STORM FLOW COMPUTATION FORMS

The hydrology and hydraulic analysis for proposed storm sewer and surface water flowage can be accomplished with or without the aid of a computer program. All computations showing the hydraulic analysis of the proposed drainage system must be submitted to obtain drainage approval. This information should be presented on the forms contained in Appendix A and Figures 4 & 5 or in a similar clearly presented format. Legible photocopies are acceptable.

#### 14. CERTIFICATIONS

Professionally prepared and certified drainage plans fulfilling the requirements of the Storm Drainage and Sediment Control Ordinance of Delaware County, Indiana, shall be submitted to the Delaware County Engineer's Office and approved by the said County Engineer. To accomplish a land alteration, certificates are required for sufficiency of plan, obligation to observe and completion and compliance. These forms are found in Appendix B.

#### 15. VARIANCES

Alternative drainage methods may be acceptable and a variance from these Standards and Regulations may be permitted by the Delaware County Commissioners. Written application for a variance must be made in accordance with the Storm Drainage and

Sediment Control Ordinance of Delaware County, Indiana, Section 4-66-13, and all amendments thereto.

#### 16. AMENDMENTS

These standards and regulations may be amended from time to time as deemed necessary by the Delaware County Engineer and/or the Delaware County Commissioners in accordance with the procedures set forth in the Storm Drainage and Sediment Control Ordinance of Delaware County, Indiana, Section 4-66-15.

#### 17. REFERENCES

Appendix C contains various frequency-duration-intensity charts for other areas such as Indianapolis and Lafayette. It also contains a rendering of a recommended site development plan for detached, scattered site dwellings. Appendix D contains a listing of the various references used in the compilation of these General Drainage Standards and Regulations for Delaware County, Indiana.

#### 18. EFFECTIVE DATE

These General Drainage Standards and Regulations of Delaware County, Indiana, shall become effective one (1) month from and after adoption by the Board of Commissioners of Delaware County, Indiana and such publication as may be required by law, with the effective date being April 1, 1993.

These General Drainage Standards and Regulations of Delaware County, Indiana, are hereby adopted this \_\_\_\_\_ day of \_\_\_\_\_, 1993.

BOARD OF COMMISSIONERS  
DELAWARE COUNTY, INDIANA

BY:

\_\_\_\_\_  
Robert Donati, President

\_\_\_\_\_  
Ron Bonham, Vice President

\_\_\_\_\_  
Robert Hartley, Chief of Staff

ATTEST:

\_\_\_\_\_  
Kent Riffin, Auditor  
Delaware County, Indiana



TABLE 1

## DETERMINATION OF RUNOFF COEFFICIENTS FOR THE RATIONAL METHOD

## URBAN RUNOFF COEFFICIENTS (C) FOR THE RATIONAL METHOD

Description of Area	Runoff Coefficient
Business	
Downtown	0.70 - 0.95
Neighborhood	0.50 - 0.70
Residential	
Single-Family	0.30 - 0.50
Multi-Family, detached	0.40 - 0.60
Multi-Family, attached	0.60 - 0.75
Residential	
Suburban	0.25 - 0.40
Apartments	0.50 - 0.70
Industrial	
Light	0.50 - 0.80
Heavy	0.60 - 0.90
Parks/Cemeteries	0.10 - 0.25
Playgrounds	0.20 - 0.35
Unimproved	0.10 - 0.30

## VALUES USED TO DETERMINE A COMPOSITE RUNOFF COEFFICIENT FOR AN URBAN AREA

Character of Surface	Runoff Coefficient
Pavement	
Asphalt and Concrete	0.70 - 0.95
Brick	0.70 - 0.85
Roofs	0.75 - 0.95
Lawns - Sandy Soil	
Flat - 2 percent	0.05 - 0.10
Average - 2 to 7 percent	0.10 - 0.15
Steep - 7+ percent	0.15 - 0.20
Lawns - Heavy Soil	
Flat - 2 percent	0.13 - 0.17
Average - 2 to 7 percent	0.18 - 0.22
Steep - 7+ percent	0.25 - 0.35
Water Impoundment	1.00

EXAMPLE: Composite Runoff Coefficient for the following:

3.2 A asphalt; 1.2 A roofs; 10.6 A lawns-heavy soil-5% slope

$$\text{Comp. C} = \frac{(.9 \times 3.2) + (.85 \times 1.2) + (.2 \times 10.6)}{15 \text{ A}} = \frac{6.02}{15} = .40$$

TABLE 1 - CONTINUED

DETERMINATION OF RUNOFF COEFFICIENTS FOR THE RATIONAL METHOD

RURAL RUNOFF COEFFICIENTS (C) FOR THE RATIONAL METHOD

Vegetation and Topography	Soil Texture		
	Open Sandy Loam	Clay & Silt Loam	Tight Clay
Woodland:			
Flat (0-5% slope)	0.10	0.30	0.40
Rolling (5-10% slope)	0.25	0.35	0.50
Hilly (10-30% slope)	0.30	0.50	0.60
Pasture:			
Flat (0-5% slope)	0.10	0.30	0.40
Rolling (5-10% slope)	0.16	0.36	0.55
Hilly (10-30% slope)	0.22	0.42	0.60
Cultivated:			
Flat (0-5% slope)	0.30	0.50	0.60
Rolling (5-10% slope)	0.40	0.60	0.70
Hilly (10-30% slope)	0.52	0.72	0.82

NOTE:

The coefficients of this table are applicable to storms of 5 to 10 year frequencies. Coefficients for less frequent higher intensity storms shall be modified as follows:

Return Period in Years	Multiply "C" By
25	1.1
50	1.2
100	1.25



TABLE 2  
 REPRESENTATIVE RUNOFF COEFFICIENTS AND INLET TIMES

Land Use	Runoff Coefficients	Percent Impervious	Inlet Times (minutes)
Business, Commercial & Industrial	0.80 - 0.90	90%	5
Apartments & Townhouses	0.65 - 0.75	75%	5 - 10
Schools & Churches	0.50 - 0.60	50%	5 - 10
Single Family Units Lots 10,000 SF	0.40 - 0.50	35%	10 - 15
Lots 17,000 SF	0.35 - 0.45	30%	10 - 15
Lots 1/2 acre & up	0.30 - 0.40	20%	10 - 15
Parks, Cemeteries, & Unimproved Areas	0.25 - 0.35	15%	10 - 15

NOTES:

1. The lowest range of runoff coefficients would be used for flat areas (areas where the majority of the grades and slopes are 2% and less).

2. The average range of runoff coefficients would be used for intermediate areas (areas where the majority of the grades and slopes are from 2% to 5%).

3. The highest range of runoff coefficients would be used for steep areas (areas where the majority of the grades and slopes are greater than 5%).

4. Inlet time values can vary from 5 to 30 minutes. A typical situation where an inlet time may be 20 to 30 minutes would be for flat residential areas with widely spaced inlets.

5. When an inlet time is greater than an upstream travel time, then the inlet time is used as the time of concentration for a subsequent calculation.

TABLE 3  
EQUATIONS FOR DETERMINING OVERLAND FLOW TIME

NAME	EQUATION FOR $t_c$	NOTES
Ragan (1972)	$t_c = \frac{L^{0.6} n^{0.6}}{i^{0.4} S^{0.3}}$	n is Mannings roughness coefficient
Kerby (1959)	$t_c = 0.827 \frac{NL^{0.467}}{S^{1/2}}$	L < 1200', see Table 3a for N values
Federal Aviation Agency	$t_c = \frac{1.8 (1.1-C) L}{(100S)^{1/3}}$	airport areas C = runoff coefficient
Izzard (1946)	$t_c = \frac{2}{60} \times \frac{.0007i+c}{S^{1/3}} L \frac{iL}{43200}^{-2/3}$	iL < 500, see Table 3c for c values
Overton & Meadows	$t_c = \frac{0.007 (n'L)^{0.8}}{P_2^{0.5} S^{0.4}}$	see Table 3b for n' values L < 300, P <sub>2</sub> = 2 yr. 24 hr. rainfall depth

Where,  $t_c$  = overland flow time (min)  
L = basin length (ft)  
S = basin slope (ft/ft)  
i = rainfall intensity (in/hr)

TABLE 3a  
VALUES OF N FOR KERBY'S FORMULA

Type of Surface	N
Smooth impervious surface	0.02
Smooth bare packed soil	0.10
Poor grass, cultivated row crops or moderately rough bare surface	0.20
Deciduous timberland	0.60
Pasture or Overage grass	0.40
Conifer timberland, deciduous timberland with deep forest litter or dense grass	0.80



TABLE 3b

## MANNING'S n ROUGHNESS COEFFICIENTS FOR SHEET FLOW

Surface Description	n' values
Smooth surfaces (concrete, asphalt, gravel, or bare soil)	0.011
Fallow (no residue)	0.05
Cultivated soils:	
Residue cover $\leq$ 20%	0.06
Residue cover $>$ 20%	0.17
Grass:	
Short grass prairie	0.15
Dense grasses	0.24
Bermuda grass	0.41
Range (natural)	0.13
Woods:	
Light underbrush	0.40
Dense underbrush	0.80

- Notes: 1. The n' values are a composite of information compiled by Engman (1986).
2. Dense grasses includes species such as weeping lovegrass, bluegrass, buffalo grass, blue grama grass, and native grass mixtures.
3. When selecting n' for Woods, consider cover to a height of about 0.1 ft. This is the only part of the plant cover that will obstruct sheet flow.

TABLE 3c

## VALUES OF c FOR IZZARD'S FORMULA

Type of Surface	c Values
Smooth asphalt surface	0.007
Concrete pavement	0.012
Tar and gravel pavement	0.017
Closely clipped sod	0.046
Dense bluegrass turf	0.060

TABLE 4

SOIL CONSERVATION SERVICE CLASSIFICATION OF SOILS  
 NATIONAL ENGINEERING HANDBOOK - HYDROLOGY: SECTION 4 (NEH-4)

<u>Soil Group</u>	<u>Characteristics</u>
A	Soils in this category have a high infiltration rate even when thoroughly wetted and consist mainly of deep, well to excessively drained sands or gravels. (Low runoff potential)
B	Soils in this category have moderate infiltration rates when thoroughly wetted and consist of moderately deep to deep, moderately well to well drained soils with moderately fine to moderately coarse textures.
C	Soils in this category have slow infiltration rates when thoroughly wetted and consist mainly of soils with a layer that impedes downward movement of water, or soils with moderately fine to fine textures.
D	Soils in this category have a very slow infiltration rate when thoroughly wetted and consist mainly of clay soils with high swelling potential, soils with a permanently high water table, soils with a clay or clay layer at or near the surface, and shallow water over nearly impervious material. (Basically hydric soils, wetlands - high runoff potential)

TABLE 5

ANTECEDENT MOISTURE CONDITION CRITERIA - SCS

<u>Antecedent Moisture Condition Class</u>	<u>5-Day Antecedent Rainfall (inches)</u>	
	<u>Dormant Season</u>	<u>Growing Season</u>
I	Less than 0.5	Less than 1.4
II	0.5 to 1.1	1.4 to 2.1
III	Over 1.1	Over 2.1



TABLE 6

## HYDROLOGIC SOIL GROUPS FOR INDIANA SOILS

Soil Name	Group	Soil Name	Group	Soil Name	Group
ABSCOTA	A	BELLEVILLE	B/D	CARMEL	C
ACKERMAN	A/D	BELMORE	B	CARMI	B
ADE	A	BERKS	C	CASCO	B
ADRIAN	A/D	BETHESDA	C	CATLIN	B
ALFORD	B	BEWLEYVILLE	B	CELINA	C
ALGANSEE	B	BILLETT	B	CERESCO	B
ALGIERS	C/D	BIRDS	C/D	CHAGRIN	B
ALIDA	B	BIRKBECK	B	CHALMERS	B/D
ALLISON	B	BLOOMFIELD	A	CHATTERTON	A
ALVIN	B	BLOUNT	C	CHEEKTOWAGA	D
AMBRAW	B/D	BOBTOWN	C	CHELSEA	A
ANDRES	B	BONNELL	C	CHETWYND	B
APTAKISIC	B	BONNIE	C/D	CINCINNATI	C
ARMIESBURB	B	BONO	D	CLARENCE	D
ASHKUM	B/D	BOOKER	D	CLERMONT	D
ATKINS	D	BOONESBORO	B	CLYDE	B/D
AUBBEENAUBBEE	B	BOOTS	A/D	COBBSFORD	D
AVA	C	BOURBON	B	COESSE	C/D
AVONBURG	D	BOWES	B	COHOCTAH	B/D
AYR	B	BOYER	B	COLOMA	A
AYRMOUNT	B	BRADY	B	COLYER	D
AYRSHIRE	C	BRANCH	B	COMFREY	B/D
BANLIC	C	BREMS	A	CONOTTON	B
BARCE	B	BRENTON	B	CONOVER	C
BARRY	B/D	BROMER	C	CONRAD	A/D
BARTLE	D	BRONSON	B	COOLVILLE	C
BATTLEGROUND	B	BROOKSTON	B/D	CORWIN	B
BAXTER	B	BRUNO	A	CORY	C
BEANBLOSSOM	B	BRYCE	D	CORYDON	D
BEASLEY	C	BURNSIDE	B	COUPEE	B
BEAUCOUP	B/D	CADIZ	B	CRAIGMILE	B/D
BECKVILLE	B	CAMDEN	B	CRANE	B
BEDFORD	C	CANA	C	CRAWLEYVILLE	B
BEECHER	C	CANEYVILLE	C	CRIDER	B
BELKNAP	C	CARLISLE	A/D	CROSBY	C

NOTES: Two hydrologic soil groups such as B/D indicate the drained/undrained situation.

Modifiers shown, e.g. bedrock substratum, refer to a specific soil series phase found in soil map legend.

TABLE 6 - CONTINUED

## HYDROLOGIC SOIL GROUPS FOR INDIANA SOILS

Soil Name	Group	Soil Name	Group	Soil Name	Group
CROSIER	C	FAXON	B/D	HICKORY	C
CUBA	B	FINCASTLE	C	HIGH GAP	C
CYCLONE	B/D	FLANAGAN	B	HILLSDALE	B
DANA	B	FORESMAN	B	HOLTON	C
DARROCH	B	FOX	B	HOMER	B
DARROCH, BEDROCK SUBSTRATUM	C	FREDERICK	B	HONONEGAH	A
DEARBORN	B	FREE	B/D	HOOPESTON	B
DEL REY	C	FULTON	D	HOOSIERVILLE	C
DEPUTY	C	GENESEE	B	HOSMER	C
DERINDA	C	GESSIE	B	HOUGHTON	A/D
DESKER	A	GILBOA	B	HOYTVILLE	C/D
DICKINSON	B	GILFORD	B/D	HUNTINGTON	B
DIGBY	B	GILFORD, STRAT. SUBSTRATUM	D	HUNTSVILLE	B
DOOR	B	GILPIN	C	IONA	B
DOWAGIAC	B	GINAT	D	IPIAVA	B
DRIFTWOOD	C/D	GLENHALL	B	IROQUOIS	B/D
DRUMMER	B/D	GLYNWOOD	C	IVA	C
DU PAGE	B	GOSPORT	C	JASPER	B
DUBOIS	C	GRANBY	A/D	JENNINGS	C
DUNNING	D	GRAVELTON	B/D	JOHNSBURG	D
EBAL	B	GRAYFORD	B	JULES	B
EDEN	C	GRISWOLD	B	JUNIUS	C
EDENTON	C	GROVECITY	B	KALAMAZOO	B
EDWARDS	B/D	GUDGEL	C	KENDALLVILLE	B
EEL	B	GUTHRIE	D	KENTLAND	A/D
ELDEAN	B	HAGERSTOWN	C	KERSTON	A/D
ELKINSVILLE	B	HANEY	B	KIBBIE	B
ELLIOTT	C	HANNA	B	KINGS	D
ELSTON	B	HARPSTER	B/D	KOKOMO	B/D
EVANSVILLE	B/D	HASKINS	C	KOSCIUSKO	B
FABIUS	B	HAUBSTADT	C	KURTZ	C
FAIRMOUNT	D	HAYMOND	B	LAFAYETTE	B
FAIRPOINT	C	HENNEPIN	B	LA HOGUE	B
FARMINGTON	C	HENSHAW	C	LANDES	B
				LASH	B

NOTES: Two hydrologic soil groups such as B/C indicate the drained/undrained situation. Modifiers shown, e.g. bedrock substratum, refer to a specific soil series phase found in soil map legend.



TABLE 6 - CONTINUED

## HYDROLOGIC SOIL GROUPS FOR INDIANA SOILS

Soil Name	Group	Soil Name	Group	Soil Name	Group
LAURAMIE	B	MILLGROVE	B/D	OSHTEMO	B
LAWRENCE	C	MILLSDALE	B/D	OTWELL	C
LENAWEE	B/D	MILTON	C	OUIATENON	A
LINDSIDE	C	MONITOR	C	OWOSSO	B
LINKVILLE	C	MONTGOMERY	D	PALMS	A/D
LINWOOD	A/D	MONTMORENCI	B	PAPINEAU	C
LISBON	B	MORLEY	C	PARKE	B
LOBDELL	B	MOROCCO	B	PARR	B
LOMAX	B	MOUNDHAVEN	A	PATE	C
LONGLOIS	B			PATTON	B/D
LOSANTVILLE	C	MUDLAVIA	B	PEKIN	C
LUCAS	D	MULVEY	B	PELLA	B/D
LYDICK	B	MUNDELEIN	B	PEOGA	C
LYLES	B/D	MUREN	B	PEOTONE	B/D
MAHALASVILLE	B/D	MUSKEGO	A/D	PETROLIA	B/D
MAPLEHILL	C	MUSKINGUM	C	PEWAMO	C/D
MARKER	B	MUSSEY	B/D	PHILO	B
MARKHAM	C	NAPOLEON	A/D	PIANKESHAW	B
MARKLAND	C	NAPPANEE	D	PIKE	B
MARKTON	C	NEGLEY	B	PINEVILLAGE	B
MARTINSVILLE	B	NESIUS	A	PINHOOK	B/D
MARTISCO	B/D	NEWARK	C	PIOPOLIS	C/D
MAUMEE	A/D	NEWGLARUS	B	PIPESTONE	B
MCGARY	C	NEWTON	A/D	PLAINFIELD	A
MEDORA	B	NICHOLSON	C	PLANO	B
MEDWAY	B	NINEVEH	B	POPE	B
MELLOTT	B	NOLIN	B	PRINCETON	A
MERMILL	B/D	OAKVILLE	A	PROCHASKA	A/D
METAMORA	B	OCKLEY	B	PROCTOR	B
METEA	B	OCTAGON	B	QUINN	B/D
MIAMI	B	ODELL	B	RAGSDALE	B/D
MIAMIAN	C	OLDENBURG	B	RAGSDALE, OVERWASH	B
MIDDLEBURY	B	ONARGA	B	RAHM	C
MILFORD	B/D	ORMAS	B	RAINSVILLE	B
MILLBROOK	B	ORRVILLE	C		

NOTES: Two hydrologic soil groups such as B/C indicate the drained/undrained situation.  
 Modifiers shown, e.g. bedrock substratum, refer to a specific soil series phase found in soil map legend.

TABLE 6 - CONTINUED

## HYDROLOGIC SOIL GROUPS FOR INDIANA SOILS

Soil Name	Group	Soil Name	Group	Soil Name	Group
RANDOLPH	C	SELFRIDGE	B	TAMA	B
RARDEN	C	SELMA	B/D	TAWAS	A/D
RAUB	C	SEWARD	B	TECUMSEH	B
RAWSON	B	SHADELAND	C	TEDROW	B
REDDICK	B/D	SHAKAMAK	C	THACKERY	B
REESVILLE	C	SHIPSHE	B	THROCKMORTON	B
RENSSELAER	B/D	SHOALS	C	TICE	B
RENSSELAER, NONSTRATIFIED SUBSTRATUM	B C	SIDELL	B	TILSIT	C
		SIMONIN	B	TIPPECANOE	B
		SISSON	B	TOLEDO	D
RICHARDSVILLE	B	SKELTON	B	TORONTO	C
RIDDLES	B	SLEETH	C	TOTO	B/D
RIDGEVILLE	B	SLOAN	B/D	TRACY	B
RIMER	C	SPARTA	A	TRAPPIST	C
RIVERDALE	A	SPINKS	A	TREATY	B/D
ROBY	C	ST. CHARLES	B	TREVLAC	B
ROCKCASTLE	D	ST. CLAIR	D	TROXEL	B
ROCKFIELD	B	STARKS	C	TUSCOLA	B
ROCKTON	B	STEFF	C	TYNER	A
RODMAN	A	STENDAL	C	UNIONTOWN	B
ROSS	B	STOCKLAND	B	VARNA	C
ROSSMOYNE	C	STONELICK	B	VIGO	D
RUARK	B/D	STOY	C	VINCENNES	C/D
RUSH	B	STRAWN	B	VOLINIA	B
RUSSELL	B	STROLE	C	WABASH	D
RYKER	B	SUMAN	B/D	WAKELAND	C
SABLE	B/D	SUMAVA	B	WALLKILL	C/D
SARANAC	C/D	SUNBURY	B	WARNERS	C/D
SARANAC, GRAVELLY SUBSTRATUM	C	SWANWICK	D	WARSAW	B
		SWITZERLAND	B	WASEPI	B
SAUGATUCK	C	SWYGERT	C	WASHTENAW	C/D
SAWABASH	B	SYLVAN	B	WATSEKA	B
SCIOTOVILLE	C	SYMERTON	B	WAUPECAN	B
SEAFIELD	B	TAFTOWN	B	WAUSEON	B/D
SEBEWA	B/D	TAGGART	C	WAWASEE	B

NOTES: Two hydrologic soil groups such as B/C indicate the drained/undrained situation. Modifiers shown, e.g. bedrock substratum, refer to a specific soil series phase found in soil map legend.



TABLE 6 - CONTINUED

## HYDROLOGIC SOIL GROUPS FOR INDIANA SOILS

Soil Name	Group	Soil Name	Group	Soil Name	Group
WAYNETOWN	C	WILBUR	B	WYNN	B
WEA	B	WILHITE	C/D	XENIA	B
WEIKERT	C/D	WILLETTE	A/D	ZABOROSKY	B
WEINBACH	C	WILLIAMSPORT	C	ZADOG	A/D
WEISBURG	C	WILLIAMSTOWN	C	ZANESVILLE	C
WELLSTON	B	WINGATE	B	ZIPP	D
WESTLAND	B/D	WIRT	B		
WHEELING	B	WOLCOTT	B/D		
WHITAKER	C	WOODMERE	B		
WHITSON	D	WOOLPER	C		

NOTES: Two hydrologic soil groups such as B/C indicate the drained/undrained situation. Modifiers shown, e.g. bedrock substratum, refer to a specific soil series phase found in soil map legend.

TABLE 7

RUNOFF CURVE NUMBERS FOR MISCELLANEOUS AGRICULTURAL LANDS  
SOIL CONSERVATION SERVICE CURVE NUMBER METHOD

COVER DESCRIPTION		CURVE NUMBERS FOR HYDROLOGIC SOIL GROUPS			
Cover Type	Hydrologic Condition	A	B	C	D
Pasture, grassland, or range-continuous forage for grazing	Poor	68	79	86	89
	Fair	49	69	79	84
	Good	39	61	74	80
Meadow-continuous grass protected from grazing and generally mowed for hay		30	58	71	78
Brush-brush/weed/grass mixture with brush the major element	Poor	48	67	77	83
	Fair	35	56	70	77
	Good	30	48	65	73
Woods-grass combination (orchard or tree farm)	Poor	57	73	82	86
	Fair	43	65	76	82
	Good	32	58	72	79
Woods	Poor	45	66	77	83
	Fair	36	60	73	79
	Good	30	55	70	77
Farmsteads-buildings, lanes, driveways, and surrounding lots	-	59	74	82	86

## NOTES:

Under Pasture:

Poor = &lt;50% ground cover or heavily grazed with no mulch

Fair = 50-75% ground cover and not heavily grazed

Good = &gt;75% ground cover and lightly or only occasionally grazed

Under Brush:

Poor = &lt;50% ground cover

Fair = 50-75% ground cover

Good = &gt;75% ground cover

Under Woods-grass combination:

CN's were computed for 50% woods and 50% grass (pasture) cover

Other combinations may be computed from CN's for Woods &amp; Pasture

Under Woods:

Poor = forest litter, small trees, brush destroyed (grazing/burn)

Fair = woods grazed but not burned, some forest litter

Good = woods protected from grazing, litter &amp; brush cover soil

General:

When actual CN is less than 30, use 30 for runoff computations



TABLE 8

RUNOFF CURVE NUMBERS FOR CULTIVATED AGRICULTURAL LANDS  
SOIL CONSERVATION SERVICE CURVE NUMBER METHOD

COVER DESCRIPTION		CURVE NUMBERS FOR HYDROLOGIC SOIL GROUPS				
Cover Type	Treatment	Hydrologic Condition	A	B	C	D
Fallow	Bare soil	-	77	86	91	94
	Crop residue cover (CR)	Poor	76	85	90	93
		Good	74	83	88	90
Row crops	Straight row (SR)	Poor	72	81	88	91
		Good	67	78	85	89
	SR + CR	Poor	71	80	87	90
		Good	64	75	82	85
	Contoured (C)	Poor	70	79	84	88
		Good	65	75	82	86
	C + CR	Poor	69	78	83	87
		Good	64	74	81	85
	Contoured & Terraced (C&T)	Poor	66	74	80	82
		Good	62	71	78	81
C&T + CR	Poor	65	73	79	81	
	Good	61	70	77	80	
Small grain	SR	Poor	65	76	84	88
		Good	63	75	83	87
	SR + CR	Poor	64	75	83	86
		Good	60	72	80	84
	C	Poor	63	74	82	85
		Good	61	73	81	84
	C + CR	Poor	62	73	81	84
		Good	60	72	80	83
	C&T	Poor	61	72	79	82
		Good	59	70	78	81
C&T + CR	Poor	60	71	78	81	
	Good	58	69	77	80	
Close-seeded, broadcast legumes, rotation meadow	SR	Poor	66	77	85	89
		Good	58	72	81	85
	C	Poor	64	75	83	85
		Good	55	69	78	83
	C&T	Poor	63	73	80	83
		Good	51	67	76	80

## NOTES:

Crop residue cover applies only if residue is on at least 5% of the surface throughout the year.

Poor: Factors impair infiltration and tend to increase runoff

Good: Factors encourage average and better than average infiltration and tend to decrease runoff

TABLE 9  
 RUNOFF CURVE NUMBERS FOR URBAN AREAS  
 SOIL CONSERVATION SERVICE CURVE NUMBER METHOD

COVER DESCRIPTION	Average % Impervious	CURVE NUMBERS FOR HYDROLOGIC SOIL GROUP			
		A	B	C	D
<i>Fully Developed Urban Areas:</i>					
Open space (lawns, parks, golf courses, cemeteries, etc.):					
Poor Condition (grass cover <50%)		68	79	86	89
Fair Condition (grass cover 50-75%)		49	69	79	84
Good Condition (grass cover >75%)		39	61	74	80
Impervious areas:					
Paved parking lots, roofs, driveways, etc. (excluding ROW)		98	98	98	98
Streets and roads:					
Paved: curbs & storm sewers (excluding ROW)		98	98	98	98
Paved: open ditches (including ROW)		83	89	92	93
Gravel (including ROW)		76	85	89	91
Dirt (including ROW)		72	82	87	89
Western desert urban areas:					
Natural desert landscaping (pervious)		63	77	85	88
Artificial desert landscaping (imperv.)		96	96	96	96
Urban districts:					
Commercial & business	85	89	92	94	95
Industrial	72	81	88	91	93
Residential districts by Average lot size:					
1/8 acre or less (townhouse)	65	77	85	90	92
1/4 acre	38	61	75	83	87
1/3 acre	30	57	72	81	86
1/2 acre	25	54	70	80	85
1 acre	20	51	68	79	84
2 acres	12	46	65	77	82
<i>Developing Urban Area:</i>					
Newly graded areas (pervious no vegetation)		77	86	91	94



TABLE 10  
TYPICAL VALUES OF MANNING'S n

Material	Normal Manning's "n"	Range "n"	Desired Maximum Velocity
Concrete & Vitrified Clay Pipes in Lengths 5' and longer	.012	.010-.013	15 fps
Concrete & Vitrified Clay Pipes in Lengths 4' and shorter	.014	.012-.015	15 fps
Monolithic Concrete Sheath Forms	.013	.010-.016	15 fps
Vitrified Brick (Bends, Junction Chambers, etc.)	.017	.011-.018	15 fps
Corrugated Metal Pipes (CMP)			
Unpaved circular or arch pipe, plain or coated	.024	.024-.027	7 fps
Circular pipe BCCMP, 25% paved	.021	.021-.023	7 fps
Circular pipe BCCMP, 100% paved	.012	.010-.012	7 fps
Hellically Corrugated Metal Pipe (HCMP)			
Unpaved		.014-.020	7 fps
25% Paved		.015-.020	7 fps
100% Paved		.010-.012	7 fps
Cement Lined		.010-.012	7 fps
Pipe to be used only as approved by the Co. Engineer			
Arch pipe BCCMPA, 40% paved	.019		7 fps
Arch pipe BCCMPA, 100% paved	.013		7 fps
Polyvinylchloride - PVC	.009		7 fps

NOTE:

BCCMP = Bituminous Coated Corrugated Metal Pipe  
BCCMPA = Bituminous Coated Corrugated Metal Pipe Arch

TABLE 11

## VALUES OF MANNING'S ROUGHNESS COEFFICIENT n

Types of Channel and Description	Minimum	Normal	Maximum
A. CLOSED CONDUITS FLOWING PARTLY FULL			
A-1. Metal			
a. Brass, smooth	0.009	0.010	0.013
b. Steel			
1. Lockbar & welded	0.010	0.012	0.014
2. Riveted & spiral	0.013	0.016	0.017
c. Cast iron			
1. Coated	0.010	0.013	0.014
2. Uncoated	0.011	0.014	0.016
d. Wrought iron			
1. Black	0.012	0.014	0.015
2. Galvanized	0.013	0.016	0.017
e. Corrugated metal			
1. Subdrain	0.017	0.019	0.021
2. Storm drain	0.021	0.024	0.030
A-2. Nonmetal			
a. Lucite	0.008	0.009	0.010
b. Glass	0.009	0.010	0.013
c. Cement			
1. Neat, surface	0.010	0.011	0.013
2. Mortar	0.011	0.013	0.015
d. Concrete			
1. Culvert, straight & free of debris	0.010	0.011	0.013
2. Culvert with bends, connections, some debris	0.011	0.013	0.014
3. Finished	0.011	0.012	0.014
4. Sewer with manholes, inlet, etc., straight	0.013	0.015	0.017
5. Unfinished, steel form	0.012	0.013	0.014
6. Unfinished, smooth wood form	0.012	0.014	0.016
7. Unfinished, rough wood form	0.015	0.017	0.020
e. Wood			
1. Stave	0.010	0.012	0.014
2. Laminated, treated	0.015	0.017	0.020
f. Clay			
1. Common drainage tile	0.011	0.013	0.017
2. Vitrified sewer	0.011	0.014	0.017
3. Vitrified sewer with manholes, inlet, etc.	0.013	0.015	0.017
4. Vitrified subdrain with open joint	0.014	0.016	0.018
g. Brickwork			
1. Glazed	0.011	0.013	0.015
2. Lined with cement mortar	0.012	0.015	0.017

TABLE 11 - CONTINUED

## VALUES OF MANNING'S ROUGHNESS COEFFICIENT n

Type of Channel and Description	Minimum	Normal	Maximum
h. Sanitary sewers coated with sewage slimes, with bends and connections	0.012	0.013	0.016
i. Paved invert, sewer, smooth bottom	0.016	0.019	0.020
j. Rubble masonry, cemented	0.018	0.025	0.030
<b>B. LINED OR BUILT-UP CHANNELS</b>			
<b>B-1. Metal</b>			
a. Smooth steel surface			
1. Unpainted	0.011	0.012	0.014
2. Painted	0.012	0.013	0.017
b. Corrugated	0.021	0.025	0.030
<b>B-2. Nonmetal</b>			
a. Cement			
1. Neat, surface	0.010	0.011	0.013
2. Mortar	0.011	0.013	0.015
b. Wood			
1. Planed, untreated	0.010	0.012	0.014
2. Planed, creosoted	0.011	0.012	0.015
3. Unplaned	0.011	0.013	0.015
4. Plank with battens	0.012	0.015	0.018
5. Lined with roofing paper	0.010	0.014	0.017
c. Concrete			
1. Trowel finish	0.011	0.013	0.015
2. Float finish	0.013	0.015	0.016
3. Finished with gravel at bottom	0.015	0.017	0.020
4. Unfinished	0.014	0.017	0.020
5. Gunite, good section	0.016	0.019	0.023
6. Gunite, wavy section	0.018	0.022	0.025
7. On good excavated rock	0.017	0.020	
8. On irregular excavated rock	0.022	0.027	
d. Concrete bottom float finished with sides of			
1. Dressed stone in mortar	0.015	0.017	0.020
2. Random stone in mortar	0.017	0.020	0.024
3. Cement rubble masonry, plastered	0.016	0.020	0.024
4. Cement rubble masonry	0.020	0.025	0.030
5. Dry rubble or riprap	0.020	0.030	0.035
e. Gravel bottom with sides of			
1. Formed concrete	0.017	0.020	0.025
2. Random stone in mortar	0.020	0.023	0.026
3. Dry rubble in riprap	0.023	0.033	0.036
f. Brick			
1. Glazed	0.011	0.013	0.015



TABLE 11 - CONTINUED

VALUES OF MANNING'S ROUGHNESS COEFFICIENT  $n$ 

Type of Channel and Description	Minimum	Normal	Maximum
2. In cement mortar	0.012	0.015	0.018
g. Masonry			
1. Cement rubble	0.017	0.025	0.030
2. Dry rubble	0.023	0.032	0.035
h. Dressed ashlar	0.013	0.015	0.017
i. Asphalt			
1. Smooth	0.013	0.013	
2. Rough	0.016	0.016	
j. Vegetal lining	0.030	-----	0.500
C. EXCAVATED OR DREDGED			
a. Earth, straight & uniform			
1. Clean, recently completed	0.016	0.018	0.020
2. Clean, after weathering	0.018	0.022	0.020
3. Gravel, uniform section, clean	0.022	0.025	0.030
4. With short grass, few weeds	0.022	0.027	0.033
b. Earth, winding & sluggish			
1. No vegetation	0.023	0.025	0.030
2. Grass, some weeds	0.025	0.030	0.033
3. Dense weeds or aquatic plants in deep channels	0.030	0.035	0.040
4. Earth bottom & rubble sides	0.028	0.030	0.035
5. Stony bottom & weedy banks	0.025	0.035	0.040
6. Cobble bottom & clean sides	0.030	0.040	0.050
c. Dragline-excavated or dredged			
1. No vegetation	0.025	0.028	0.033
2. Light brush on banks	0.035	0.050	0.060
d. Rock cuts			
1. Smooth & uniform	0.025	0.035	0.040
2. Jagged & irregular	0.035	0.040	0.050
e. Channels not maintained, weeds & brush uncut			
1. Dense weeds, high as flow depth	0.050	0.080	0.120
2. Clean bottom, brush on sides	0.040	0.050	0.080
3. Same, highest stage of flow	0.045	0.070	0.110
4. Dense brush, high stage	0.080	0.100	0.140

TABLE 11 - CONTINUED

## VALUES OF MANNING'S ROUGHNESS COEFFICIENT n

Type of Channel and Description	Minimum	Normal	Maximum
<b>D. NATURAL STREAMS</b>			
D-1. Minor Streams (top width at flood stage <100 ft)			
a. Streams on plain			
1. Clean, straight, full stage, no rifts of deep pools	0.025	0.030	0.033
2. Same as above, with more stones & weeds	0.030	0.035	0.040
3. Clean, winding, some pools & shoals	0.033	0.040	0.045
4. Same as above, with some weeds & stones	0.035	0.045	0.050
5. Same as above, lower stages, more ineffective slopes & sections	0.040	0.048	0.055
6. Same as 4, with more stones	0.045	0.050	0.060
7. Sluggish reaches, weedy, deep pools	0.050	0.070	0.080
8. Very weedy reaches, deep pools, or floodways with heavy stand of timber & underbrush	0.075	0.100	0.150
b. Mountain streams no channel vegetation, banks usually steep, trees & brush along banks submerged at high stages			
1. Bottom: gravels, cobbles & few boulders	0.030	0.040	0.050
2. Bottom: cobbles with large boulders	0.040	0.050	0.070
D-2. Flood Plains			
a. Pasture, no brush			
1. Short grass	0.025	0.030	0.035
2. High grass	0.030	0.035	0.050
b. Cultivated areas			
1. No crop	0.020	0.030	0.040
2. Mature row crops	0.025	0.035	0.045
3. Mature field crops	0.030	0.040	0.050
c. Brush			
1. Scattered brush, heavy weeds	0.035	0.050	0.070
2. Light brush & trees, in winter	0.035	0.050	0.060
3. Light brush & trees, in summer	0.040	0.060	0.080
4. Medium to dense brush, in winter	0.045	0.070	0.110

TABLE 11 - CONTINUED

VALUES OF MANNING'S ROUGHNESS COEFFICIENT n

Type of Channel and Description	Minimum	Normal	Maximum
5. Medium to dense brush, in summer	0.070	0.100	0.160
d. Trees			
1. Dense willows, summer, straight	0.110	0.150	0.200
2. Cleared land with tree stumps, no sprouts	0.030	0.040	0.050
3. Same as above, with heavy growth of sprouts	0.050	0.060	0.080
4. Heavy stand of timber, a few down trees, little undergrowth, flood stage below branches	0.080	0.100	0.120
5. Same as above, with flood stage reaching branches	0.100	0.120	0.160
D-3. Major streams (top width at flood stage >100 ft) - the n value is less than that for minor streams of similar description because banks offer less effective resistance			
a. Regular section with no boulders or brush	0.025	-----	0.060
b. Irregular & rough section	0.035	-----	0.100



TABLE 12  
COMPUTATION OF COMPOSITE ROUGHNESS COEFFICIENT  
FOR EXCAVATED AND NATURAL CHANNELS

$$n = (n_1 + n_2 + n_3 + n_4 + n_5)m$$

	CHANNEL CONDITIONS	VALUE
Material Involved $n_1$	Earth	0.020
	Rockcut	0.025
	Fine Gravel	0.024
	Coarse Gravel	0.028
Degree of Irregularity $n_2$	Smooth	0.000
	Minor	0.005
	Moderate	0.010
	Severe	0.020
Variation of Channel Cross Section $n_3$	Gradual	0.000
	Alternating Occasionally	0.005
	Alternating Frequently	0.010-0.015
Relative Effect of Obstructions $n_4$	Negligible	0.000
	Minor	0.010-0.015
	Appreciable	0.020-0.030
	Severe	0.040-0.060
Vegetation $n_5$	Low	0.005-0.010
	Medium	0.010-0.025
	High	0.025-0.050
	Very High	0.050-0.100
Degree of Meandering $m$	Minor	1.000-1.200
	Appreciable	1.200-1.500
	Severe	1.500

Roughness Coefficient for Lined Channels:

Concrete Lined = 0.017  
Rubble Riprap = 0.022

Open Channel Hydraulics  
Ven Te Chow, Ph.D.

TABLE 13  
JUNCTION OR STRUCTURE COEFFICIENT OF LOSS

Case Number	Description of Condition	Coefficient K <sub>j</sub>
I	Inlet on Main Line*	0.50
II	Inlet on Main Line with Branch Lateral*	0.25
III	Manhole on Main Line with 45 Degree Branch Lateral	0.50
IV	Manhole on Main Line with 90 Degree Branch Lateral	0.25
V	45 Degree Wye Connection or Cut-in	0.75
VI	Inlet or Manhole at Beginning of Line	1.25
VII	Conduit on Curves for 90 **	
	Curve Radius = diameter	0.50
	Curve Radius = (2-8) diameter	0.40
	Curve Radius = (8-20) diameter	0.25
VIII	Bends where Radius is equal to Diameter	
	90 Degree Bend	0.50
	60 Degree Bend	0.48
	45 Degree Bend	0.35
	22.5 Degree Bend	0.20
	Manhole on Line with 60 Degree Lateral	0.35
	Manhole on Line with 22.5 Degree Lateral	0.75

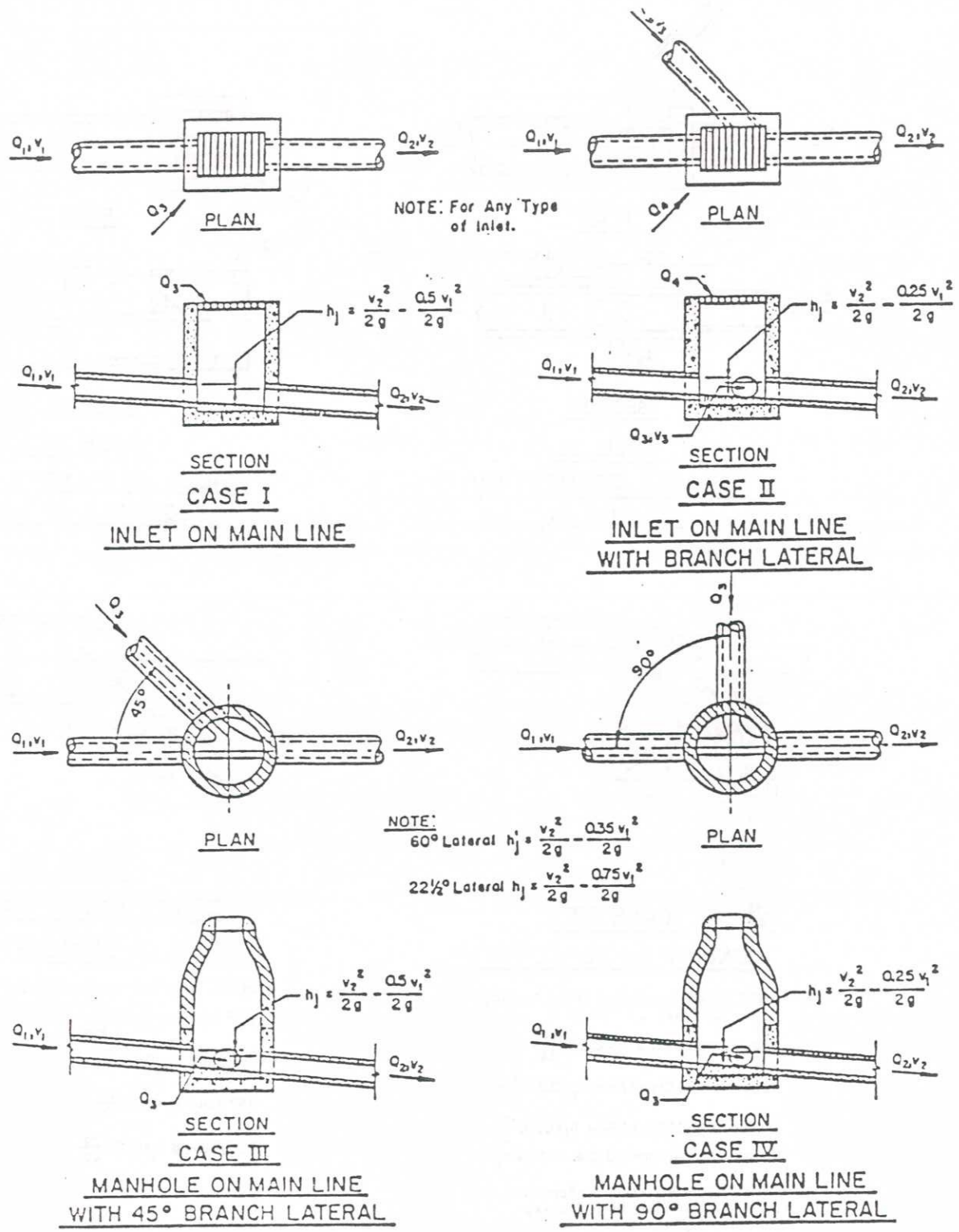
\* Must be approved by the County Engineer

\*\* Where bends other than 90 degree are used, the 90 degree bend coefficient can be used with the following percentage factor applied:

60 Degree Bend = 85%  
22.5 Degree Bend = 40%

45 Degree Bend = 70%

TABLE 13 - CONTINUED  
 JUNCTION OR STRUCTURE COEFFICIENT OF LOSS

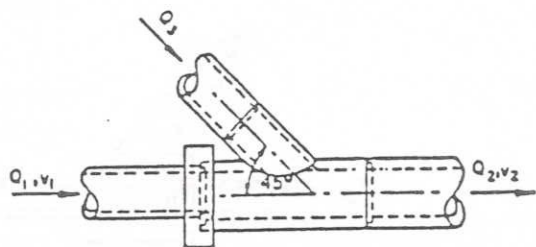


MINOR HEAD LOSSES DUE TO TURBULENCE AT STRUCTURES

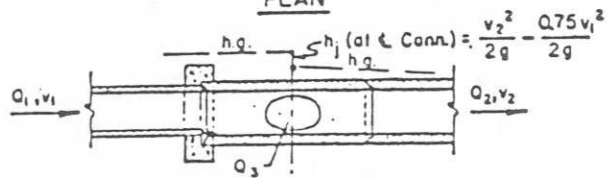


TABLE 13 - CONTINUED

JUNCTION OR STRUCTURE COEFFICIENTS OF LOSS



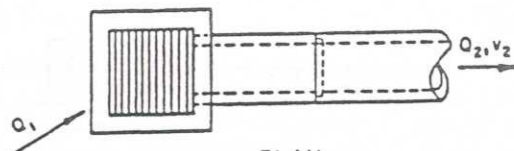
PLAN



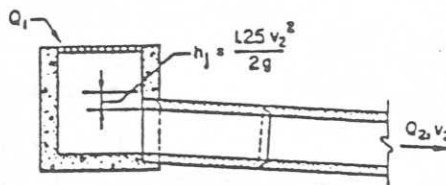
SECTION

CASE V

45° WYE CONNECTION  
OR CUT IN



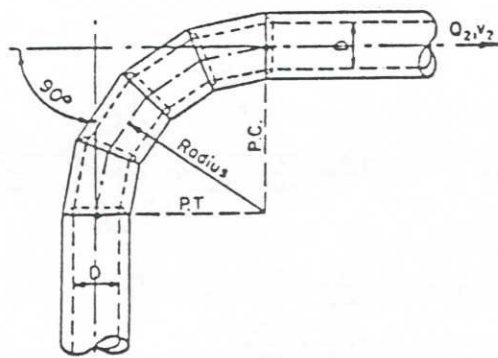
PLAN



SECTION

CASE VI

INLET OR MANHOLE AT  
BEGINNING OF LINE



CASE VII

CONDUIT ON 90° CURVES\*

NOTE: Head loss applied at P.C. for length of curve.

Radius = Dia. of Pipe  $h_j = 0.50 \frac{v_2^2}{2g}$

Radius = (2-8) Dia. of Pipe  $h_j = 0.25 \frac{v_2^2}{2g}$

Radius = (8-20) Dia. of Pipe  $h_j = 0.40 \frac{v_2^2}{2g}$

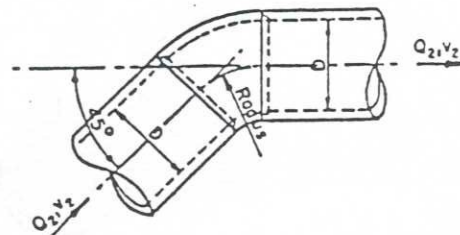
Radius = Greater than 20 Dia. of Pipe  $h_j = 0$

\* When curves other than 90° are used, apply the following factors to 90° curves.

60° curve 85%

45° curve 70%

22½° curve 40%



CASE VIII

BENDS WHERE RADIUS IS  
EQUAL TO DIAMETER OF PIPE

NOTE: Head loss applied at beginning of bend.

90° Bend  $h_j = 0.50 \frac{v_2^2}{2g}$

60° Bend  $h_j = 0.43 \frac{v_2^2}{2g}$

45° Bend  $h_j = 0.35 \frac{v_2^2}{2g}$

22½° Bend  $h_j = 0.20 \frac{v_2^2}{2g}$

MINOR HEAD LOSSES DUE TO  
TURBULENCE AT STRUCTURES

TABLE 14  
 RAINFALL INTENSITY IN INCHES/HOUR - MUNCIE/DELAWARE COUNTY

DURATION	RETURN PERIODS FREQUENCY IN YEARS					
	2	5	10	25	50	100
5 min.	4.80	6.00	6.96	7.80	8.64	9.48
10 min.	3.72	4.62	5.34	5.94	6.60	7.26
15 min.	3.08	3.80	4.40	4.92	5.44	6.00
30 min.	2.12	2.64	3.06	3.44	3.78	4.18
60 min.	1.34	1.66	1.93	2.16	2.38	2.63
2 hr.	.82	1.01	1.18	1.32	1.46	1.61
3 hr.	.59	.73	.85	.95	1.05	1.16
6 hr.	.35	.44	.51	.57	.63	.70
10 hr.	.24	.30	.34	.38	.42	.47
14 hr.	.18	.23	.26	.29	.32	.36
18 hr.	.15	.19	.22	.24	.27	.29
24 hr.	.12	.15	.17	.19	.21	.23

TABLE 15  
 RAINFALL DEPTHS IN INCHES - MUNCIE/DELAWARE COUNTY

DURATION	RETURN PERIODS					
	2	5	10	25	50	100
5 min.	.40	.50	.58	.65	.72	.79
10 min.	.62	.77	.89	.99	1.10	1.21
15 min.	.77	.95	1.10	1.23	1.36	1.50
30 min.	1.06	1.32	1.53	1.72	1.89	2.09
60 min.	1.34	1.66	1.93	2.16	2.38	2.63
2 hr.	1.64	2.03	2.36	2.64	2.91	3.22
3 hr.	1.76	2.19	2.54	2.85	3.14	3.47
6 hr.	2.13	2.64	3.06	3.43	3.78	4.18
10 hr.	2.38	2.96	3.43	3.84	4.23	4.68
14 hr.	2.55	3.17	3.67	4.12	4.54	5.02
18 hr.	2.70	3.35	3.89	4.36	4.80	5.31
24 hr.	2.87	3.56	4.13	4.63	5.10	5.64

NOTE: The above charts were derived by using the ratios for conversion of six-hour rainfall depths in accordance with the procedures set forth in the Storm Drainage Manual prepared by Christopher B. Burke for Purdue University's HERPIC and based upon the National Engineering Handbook, Hydrology, Soil Conservation Service and the U. S. Weather Bureau Technical Paper No. 40. These figures were used to plot the Intensity-Duration-Frequency Curves for Muncie, Indiana (see Figure 1).

TABLE 16

## MAXIMUM PERMISSIBLE VELOCITIES IN VEGETAL-LINED CHANNELS

Cover	Slope Range (percent)	PERMISSIBLE VELOCITIES <sup>1</sup>	
		Erosion Resistant Soils (fps)	Easily Eroded Soils (fps)
Bermudagrass	0-5	8	6
	5-10	7	5
	over 10	6	4
Bahia Buffalograss Kentucky Bluegrass Smooth brome Blue gama	0-5	7	5
	5-10	6	4
	over 10	5	3
Grass mixtures <sup>2</sup> Reed canarygrass <sup>2</sup>	0-5	5	4
	5-10	4	3
Lespediza sericea <sup>3</sup> Weeping lovegrass <sup>3</sup> yellow bluestem <sup>3</sup> Redtop <sup>3</sup> Alfalfa <sup>3</sup> Red fescue <sup>3</sup>	0-5	3.4	2.5
Common lespedeza <sup>4</sup> Sudangrass <sup>4</sup>	0-5	3.5	2.5

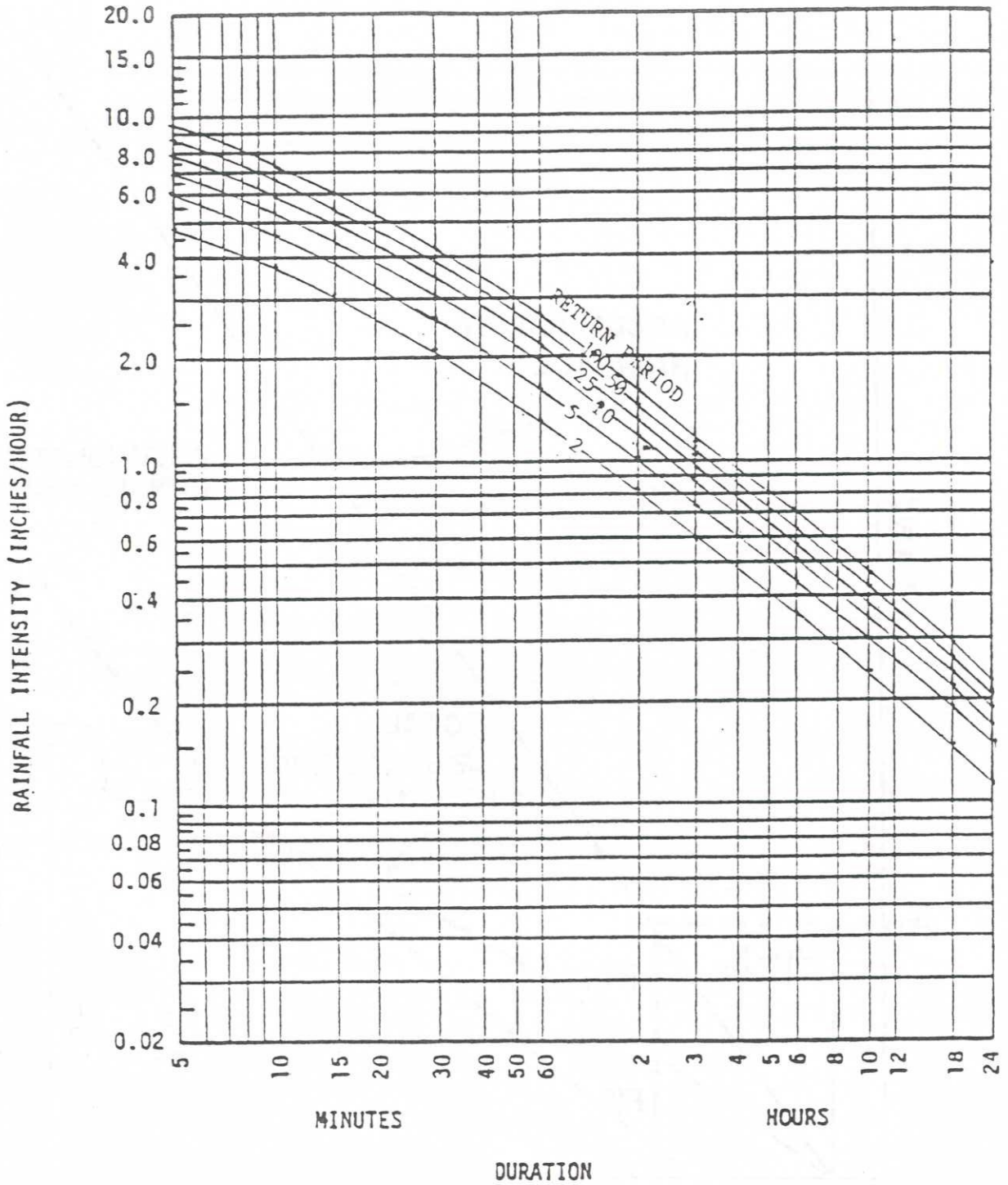
1. Use velocities exceeding 5 feet per second only where good cover and proper maintenance can be obtained.
2. Do not use on slopes steeper than 10 percent except for vegetated side slopes in combination with a stone, concrete, or highly resistant vegetative center section.
3. Do not use on slopes steeper than 5 percent except for vegetated side slopes in combination with stone, concrete, or highly resistant vegetative center section.
4. Annuals - use on mild slopes or as temporary protection until permanent covers are established. Use on slopes steeper than 5 percent is not recommended.

NOTE: From Soil Conservation Service, SCS-TP-61, Handbook of Channel Design for Soil & Water Conservation.



FIGURE 1

FREQUENCY - INTENSITY - DURATION CURVE  
MUNCIE/DELAWARE COUNTY, INDIANA



PLACE: MUNCIE, DELAWARE COUNTY, INDIANA

PERIOD: 2 YR, 5 YR, 10 YR, 25 YR, 50 YR, 100 YR

FIGURE 2

SCS CURVE NUMBER DIAGRAM OF ACCUMULATED RAINFALL, RUNOFF & INFILTRATION

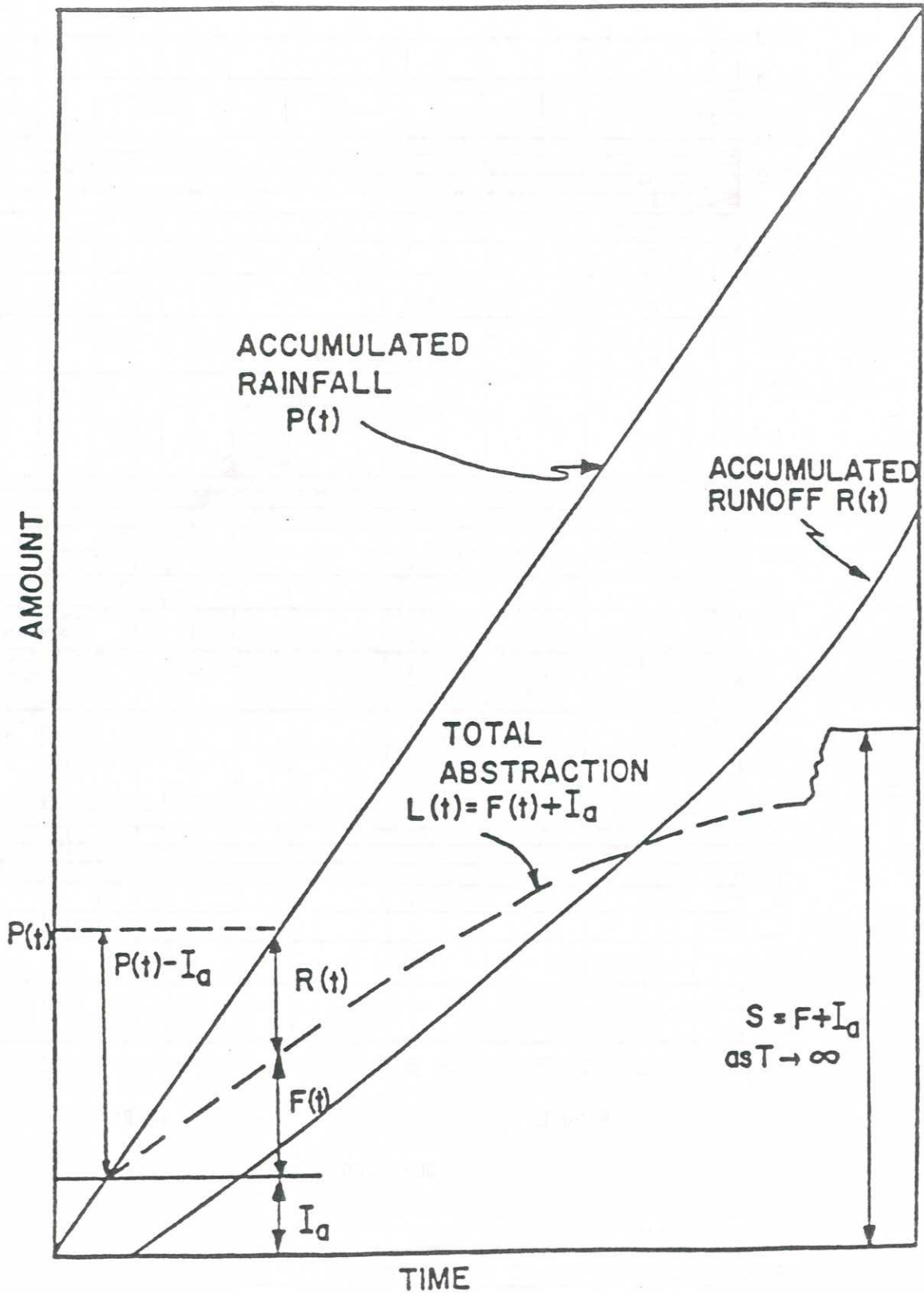




FIGURE 2a

SCS CURVE NUMBER METHOD  
GRAPHICAL SOLUTION FOR RUNOFF

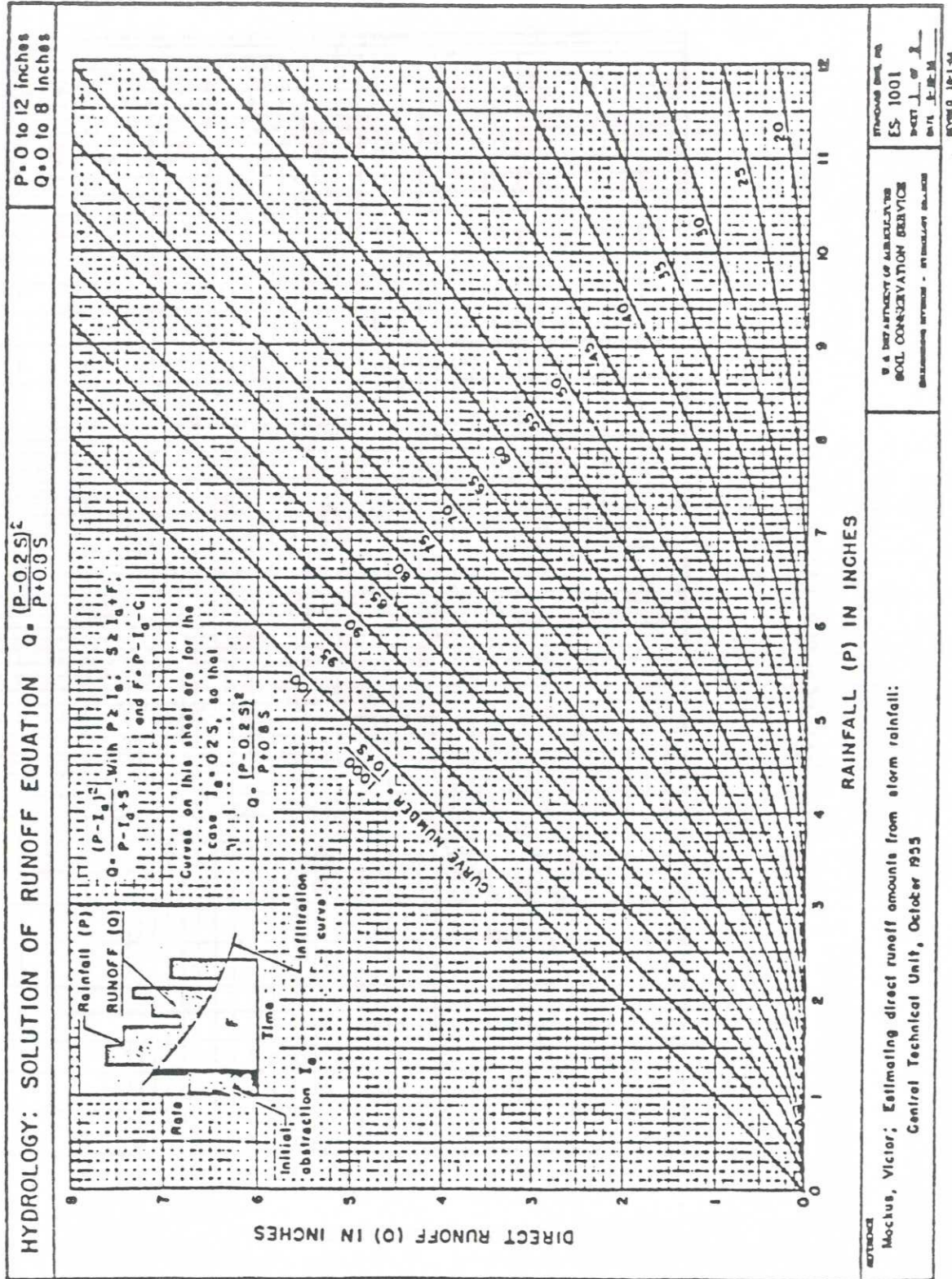




FIGURE 3

AVERAGE VELOCITIES FOR ESTIMATING TRAVEL TIME  
SOIL CONSERVATION SERVICE

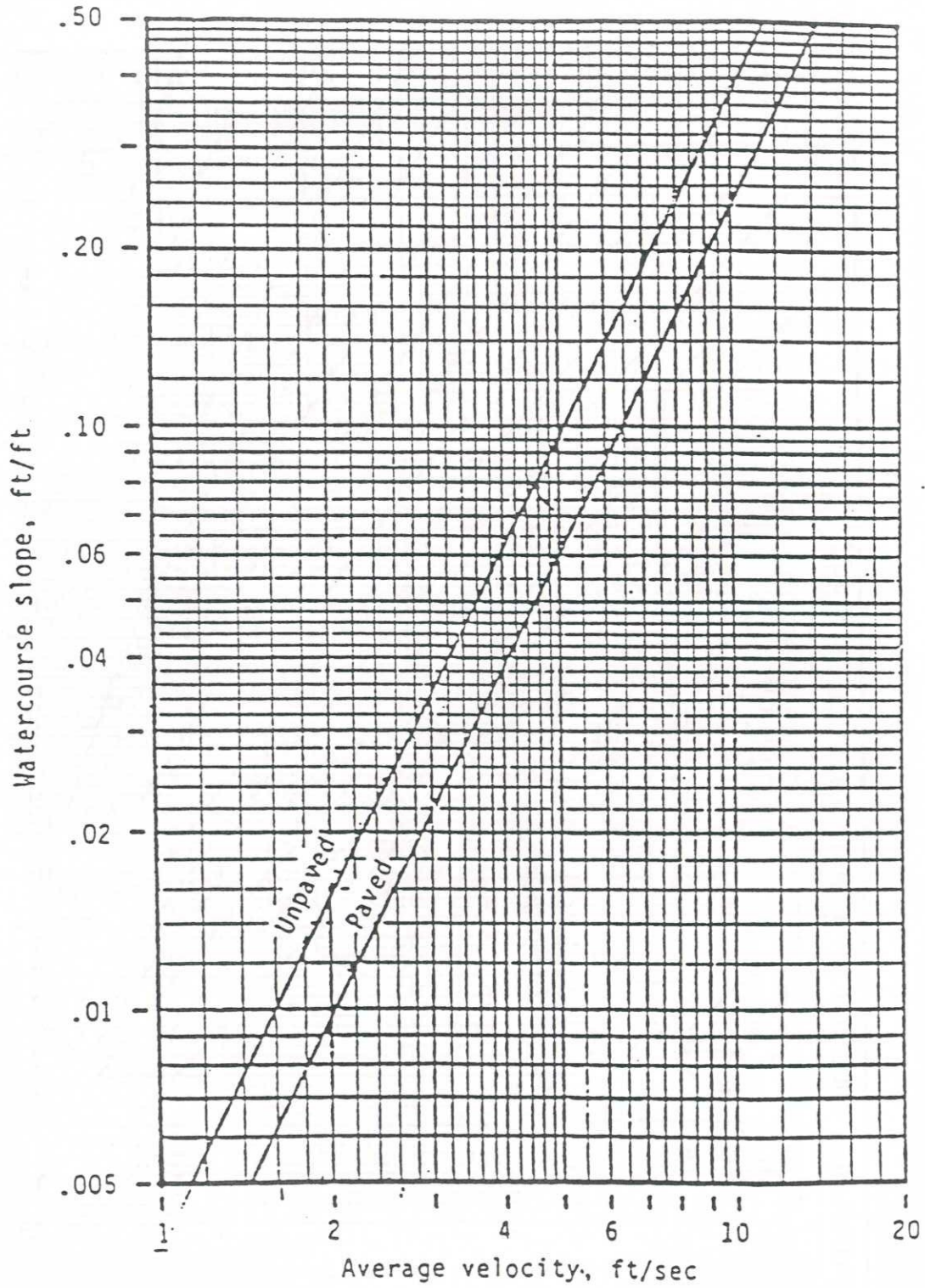


FIGURE 4

COMPUTATION FORM FOR STORAGE CALCULATIONS - RATIONAL METHOD

PROJECT LOCATION: \_\_\_\_\_

DESIGNER: \_\_\_\_\_

DETENTION FACILITY DESIGN RETURN PERIOD: 50 YEAR OR \_\_\_\_\_

RELEASE RATE RETURN PERIOD: 5 YR OR \_\_\_\_\_

Watershed/Basin Area = \_\_\_\_\_

Time of Concentration of Undeveloped Watershed: \_\_\_\_\_

Undeveloped Rainfall Intensity ( $i_u$ ): \_\_\_\_\_

Undeveloped Runoff Coefficient ( $C_u$ ): \_\_\_\_\_

Undeveloped Runoff Rate ( $O=C_u i_u A_u$ ) in cfs: \_\_\_\_\_

Developed Runoff Coefficient ( $C_D$ ): \_\_\_\_\_

Storm Duration $t_d$	Rainfall Intensity $i_D$	Inflow Rate $I(t_d)$ ( $C_D i_D A_D$ )	Outflow Rate $O$ ( $C_u i_u A_u$ )	Storage Rate $I(t_d) - O$	Required Storage $[I(t_d) - O] \times \frac{t_d}{12}$
hours	in/hr	cfs	cfs	cfs	acre/ft

When outflow is greater than inflow, no storage is required. The greatest amount of acre/ft found is the required storage.

FIGURE 5

COMPUTATION FORM FOR STORAGE CALCULATIONS - SCS CURVE NUMBER METHOD

PROJECT LOCATION: \_\_\_\_\_

DESIGNER: \_\_\_\_\_

DETENTION FACILITY DESIGN RETURN PERIOD: 50 YEAR OR \_\_\_\_\_

RELEASE RATE RETURN PERIOD: 5 YR OR \_\_\_\_\_

Watershed/Basin Area = \_\_\_\_\_

Undeveloped Runoff Rate (O) = \_\_\_\_\_

Method of Calculation of O: \_\_\_\_\_

Developed Curve Number (CN) = \_\_\_\_\_

Ultimate Abstraction S = \_\_\_\_\_

(S = 1000/CN - 10)

Storm Duration $t_d$ hours	Rainfall Intensity $i_s$ in/hr	Rainfall Amount P $P(t_d)$ in	Cum. Runoff R $R(t_d)$ in	Inflow Volume I $R(A_d)$ in/acr	Outflow Volume O $O t_d$ cfs/hr	Vol. Diff. I-O	Required Storage $s(t_d)$ $[I-O] \times \frac{1}{12}$ acre/ft

NOTES:  $R(t_d) = \frac{[P(t_d) - 0.2S]^2}{[P(t_d) + 0.8S]}$

When outflow is greater than inflow, no storage is required. The greatest amount of acre/ft found under  $s(t_d)$  is the required storage.



FIGURE 6

TYPICAL RECHARGE TRENCH FOR AN INFILTRATION SYSTEM  
DESIGN OF ON-SITE DISCHARGE DITCH

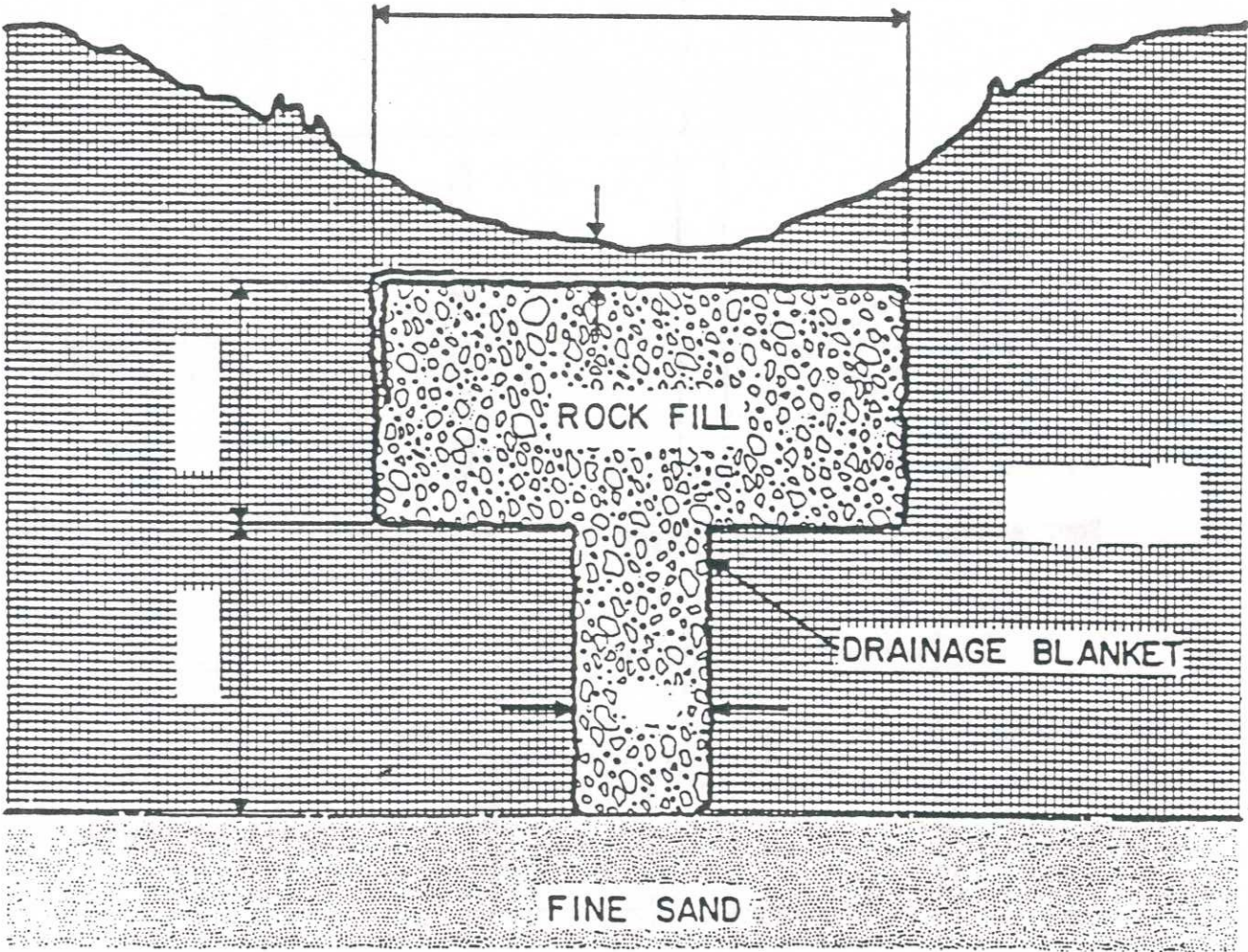


FIGURE 6a

TYPICAL ORIFICE - TYPICAL WEIR

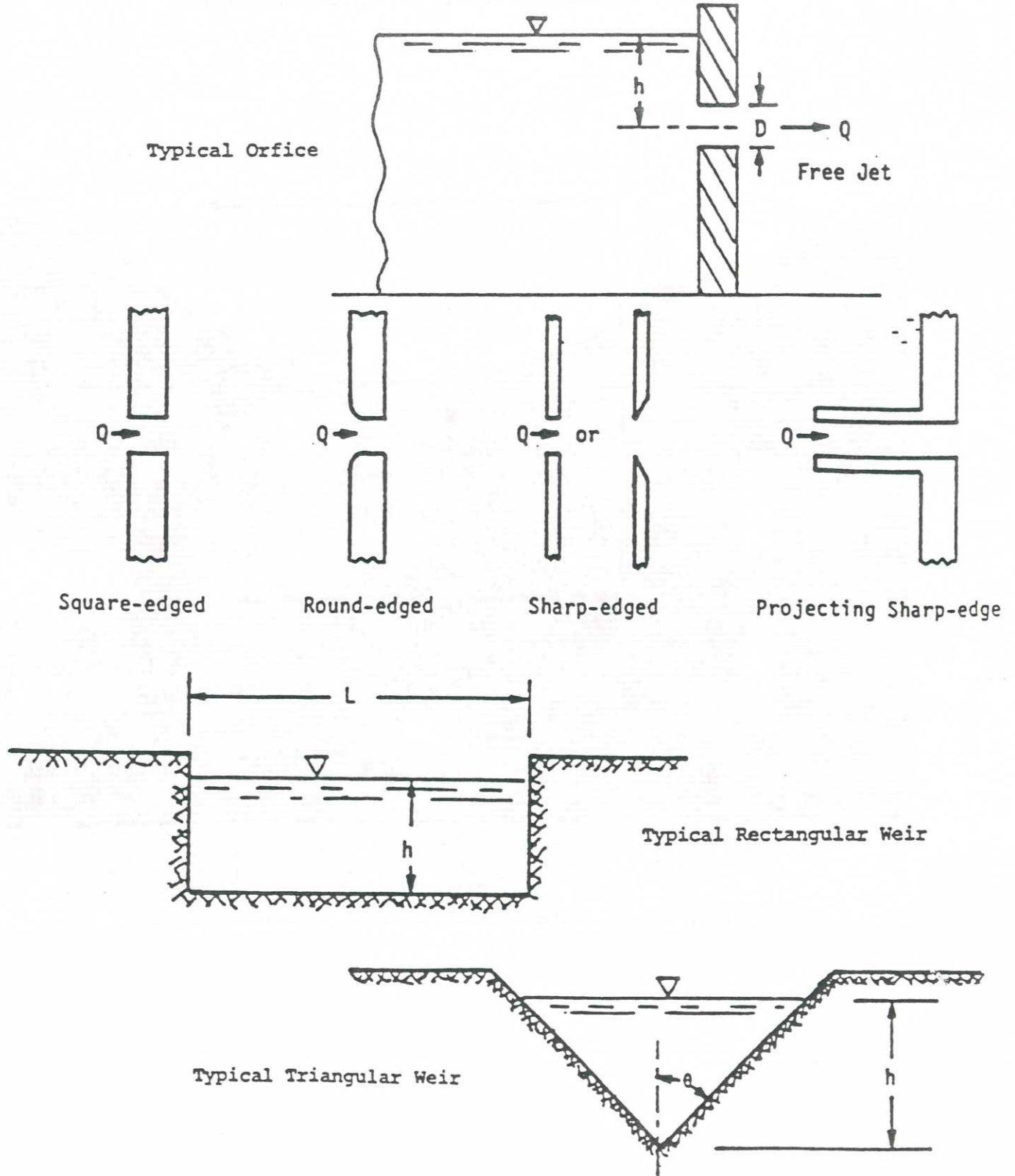


FIGURE 7

SELECTION OF EROSION CONTROL SYSTEM BY SLOPE AND DEPTH

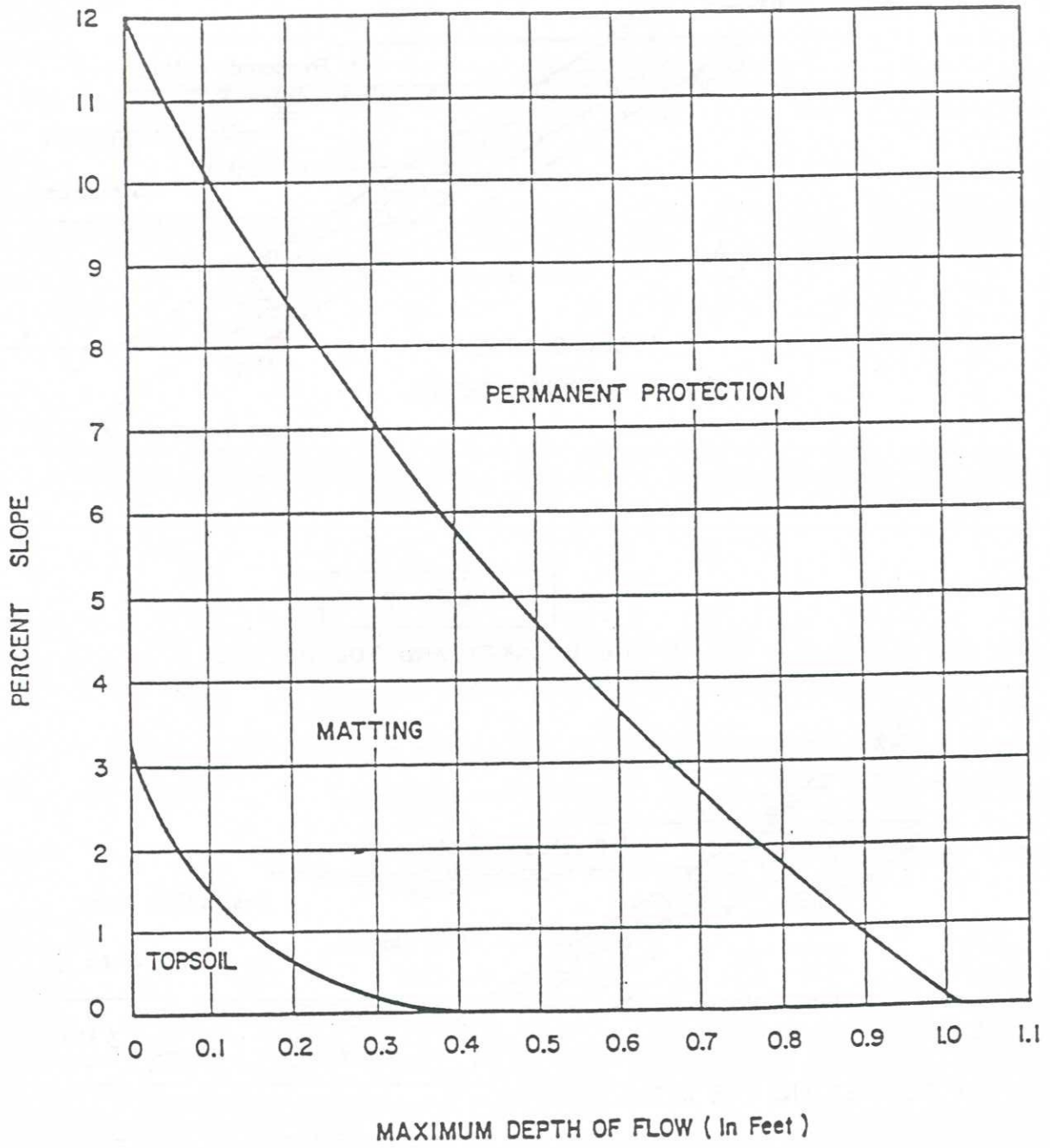
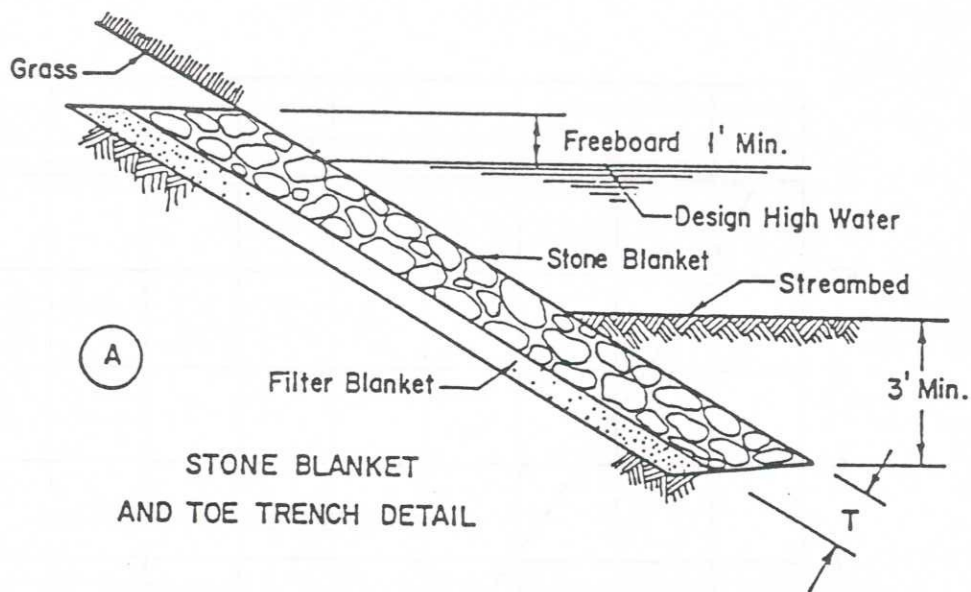




FIGURE 8

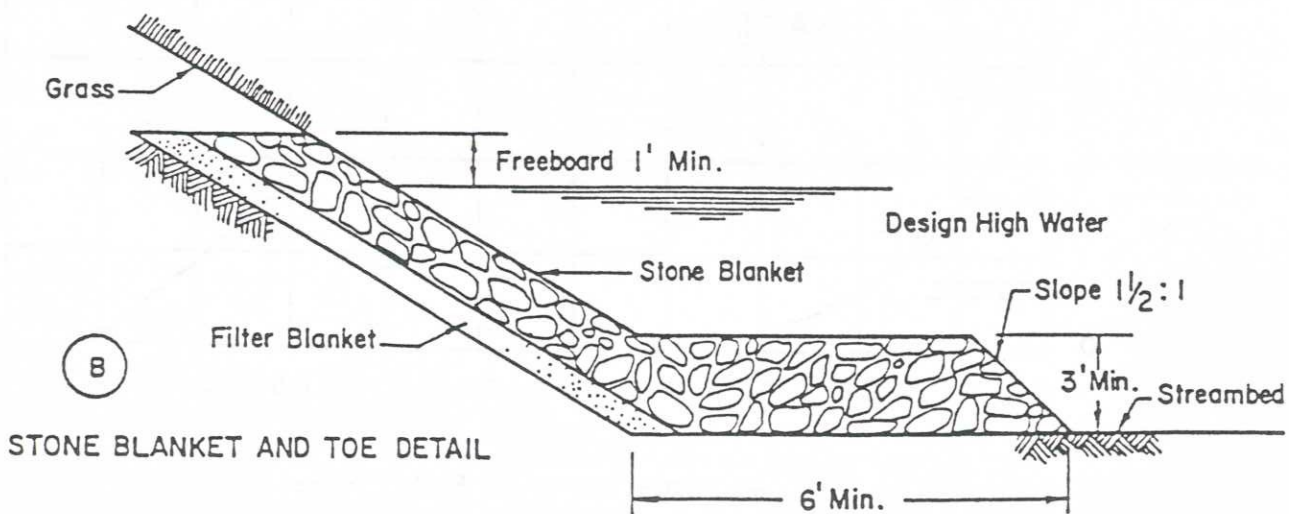
STONE BLANKET AND TOE TRENCH DETAIL



STONE BLANKET  
AND TOE TRENCH DETAIL

FIGURE 9

STONE BLANKET AND TOE DETAIL



STONE BLANKET AND TOE DETAIL

FIGURE 10

TERMINAL CUTOFF OF RIP RAP BLANKET DETAIL

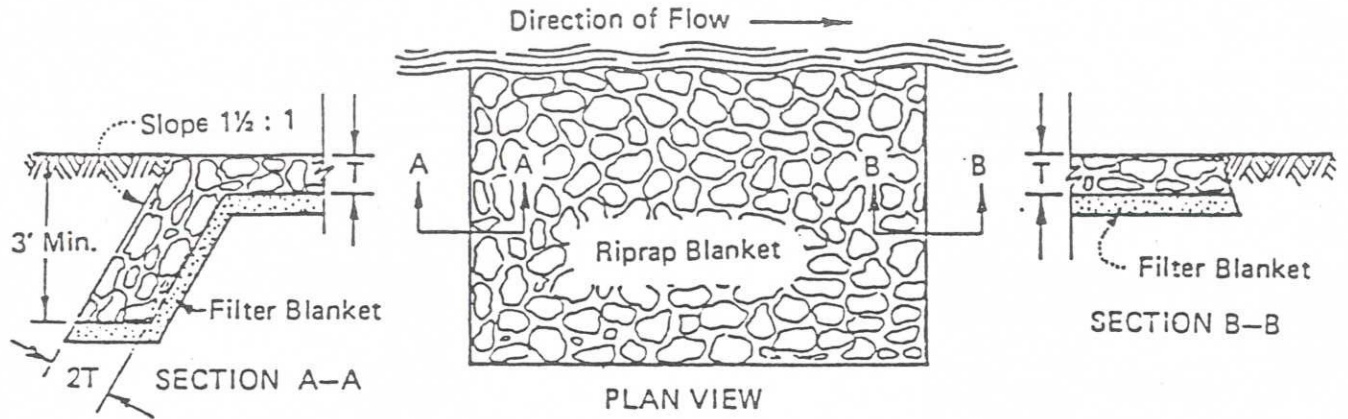
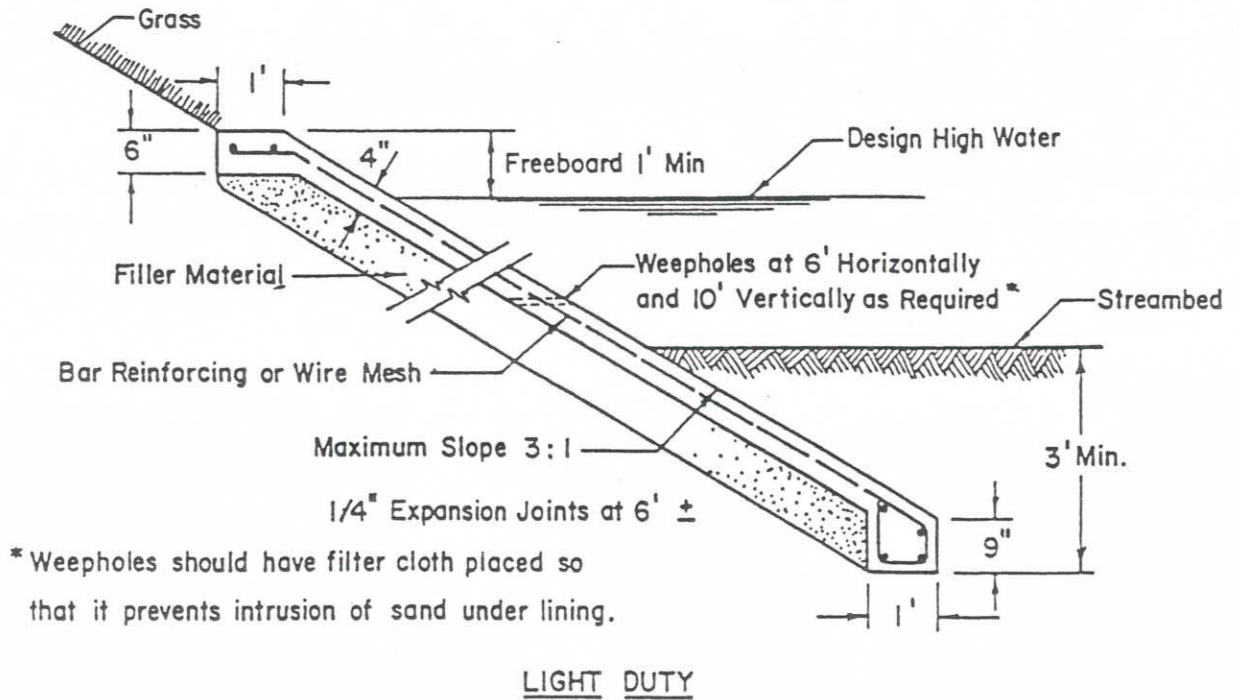


FIGURE 11

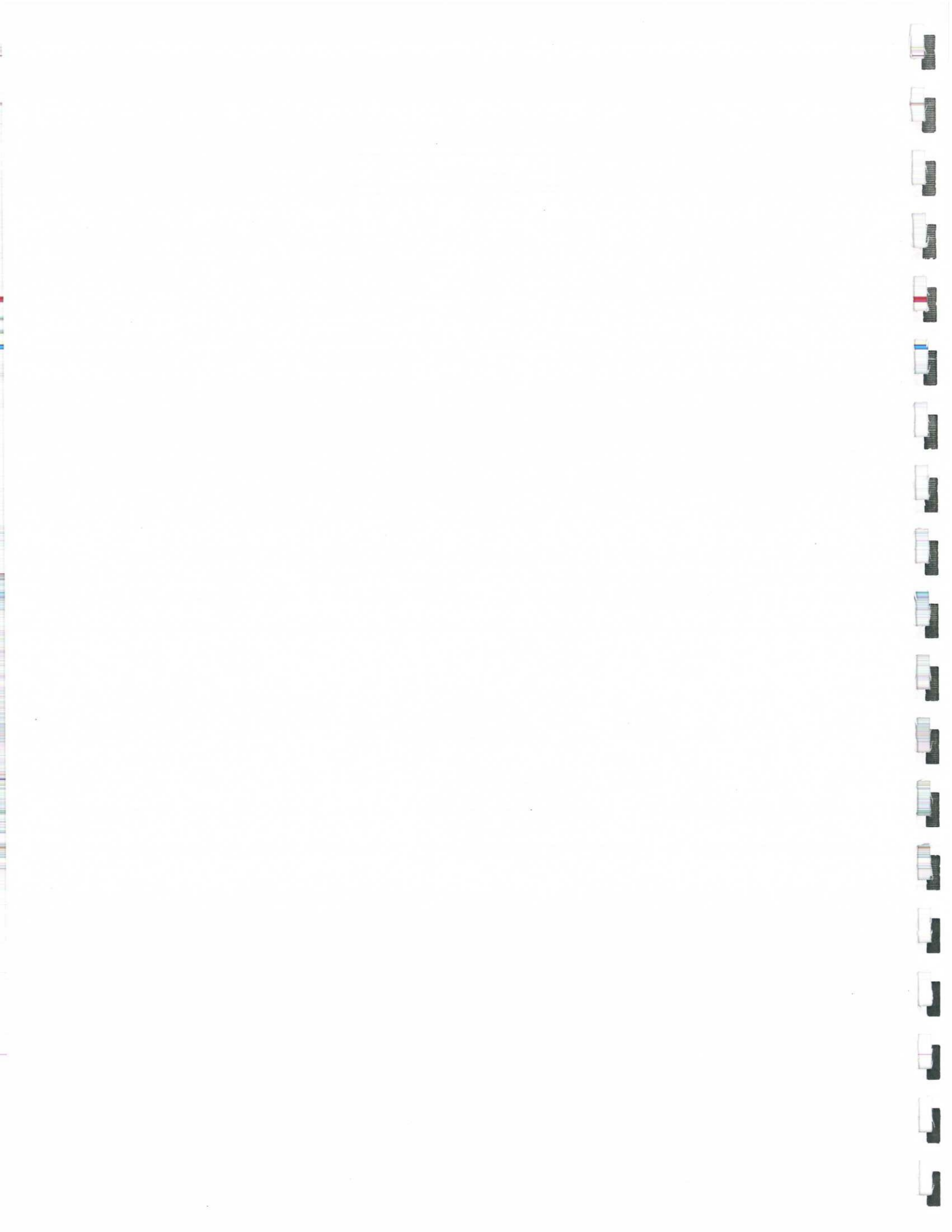
CONCRETE PAVING SLOPE PROTECTION







APPENDIX A



## STORM DRAIN FLOW TABULATION FORM

LOCATION \_\_\_\_\_ DATE \_\_\_\_\_ 19 \_\_\_\_\_  
 DEVELOPMENT \_\_\_\_\_ SHEET \_\_\_\_\_ TOTAL IN COMP. \_\_\_\_\_  
 MADE IN CONNECTION WITH J.O. NO. \_\_\_\_\_ COMPUTED BY \_\_\_\_\_  
 STORM FREQUENCY \_\_\_\_\_ CHECKED BY \_\_\_\_\_

LOCATION From	To	AREA		ACRES		COEFF. "C"	CA	CA	TIME CONC.- MIN.		INTEN. "I"	Q = CIA C.F.S.	PIPE n <sup>2</sup>			REMARKS	
		Sub.	Total	Inlet	Drain				Total	Size			Slope	Vel.	Lgth.		

DELAWARE COUNTY INDIANA	STANDARD STORM DRAINAGE DESIGN FLOW TABULATION FORM				
	REVISED <table style="width: 100%; border-collapse: collapse;"> <tr><td style="width: 50%; border: none;"></td><td style="width: 50%; border: none; text-align: center;">DD</td></tr> <tr><td style="width: 50%; border: none;"></td><td style="width: 50%; border: none; text-align: center;">7</td></tr> </table>		DD		7
	DD				
	7				





# TIME OF CONCENTRATION FORM

LOCATION \_\_\_\_\_  
 DEVELOPMENT \_\_\_\_\_  
 LOT SIZE \_\_\_\_\_  
 JCB ORDER NO. \_\_\_\_\_

DATE \_\_\_\_\_  
 SHEET \_\_\_\_ TOTAL IN COMP \_\_\_\_  
 COMPUTED BY \_\_\_\_\_  
 CHECKED BY \_\_\_\_\_

DESIGN POINT	OVERLAND FLOW	SWALE FLOW	GUTTER FLOW	DRAIN FLOW	REMARKS	TOTAL T.C.





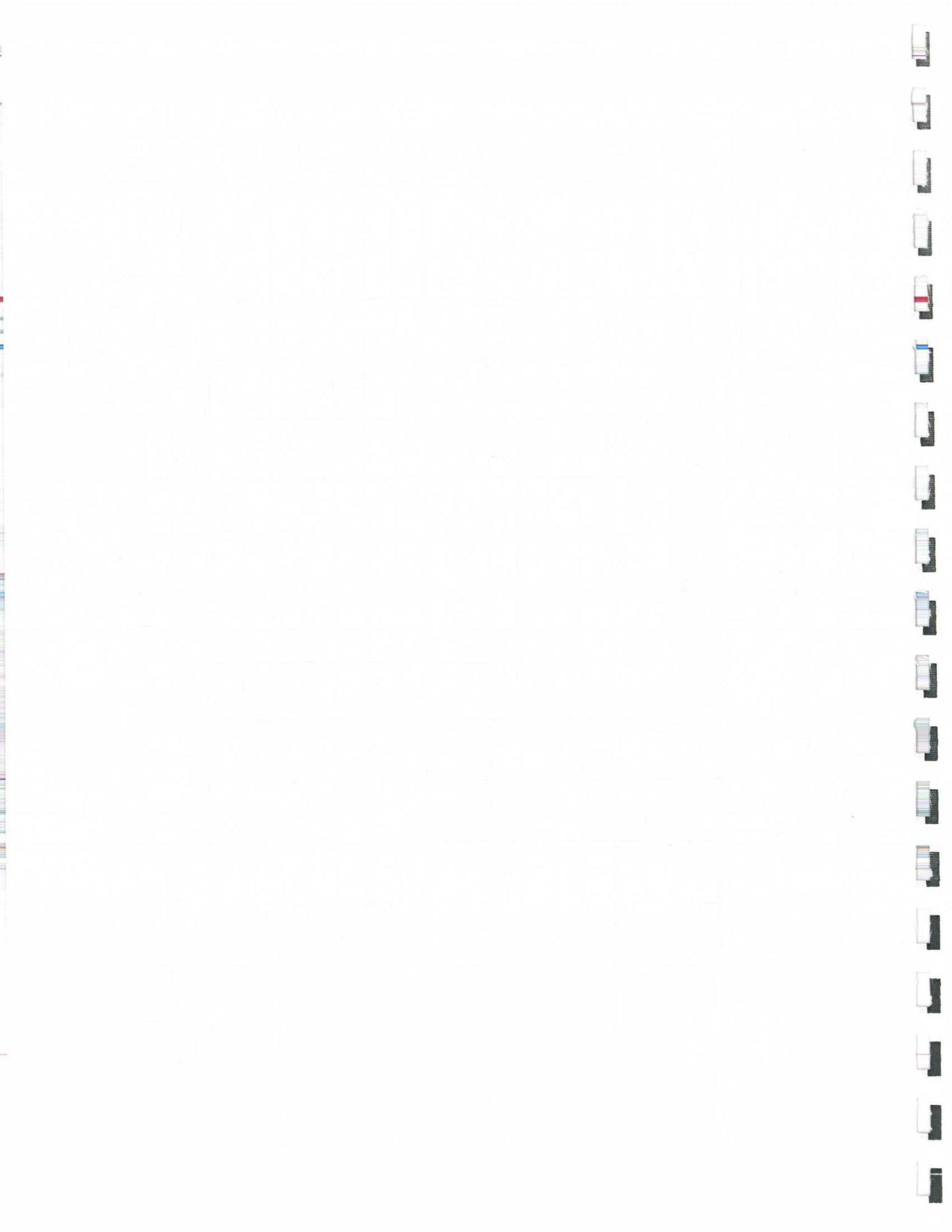
# INLET AND GUTTER CAPACITY FORM

LOCATION \_\_\_\_\_  
 DEVELOPMENT \_\_\_\_\_  
 LOT SIZE \_\_\_\_\_  
 JOB ORDER NO. \_\_\_\_\_

DATE \_\_\_\_\_  
 SHEET \_\_\_\_\_ TOTAL IN COMP. \_\_\_\_\_  
 COMPUTED BY \_\_\_\_\_  
 CHECKED BY \_\_\_\_\_

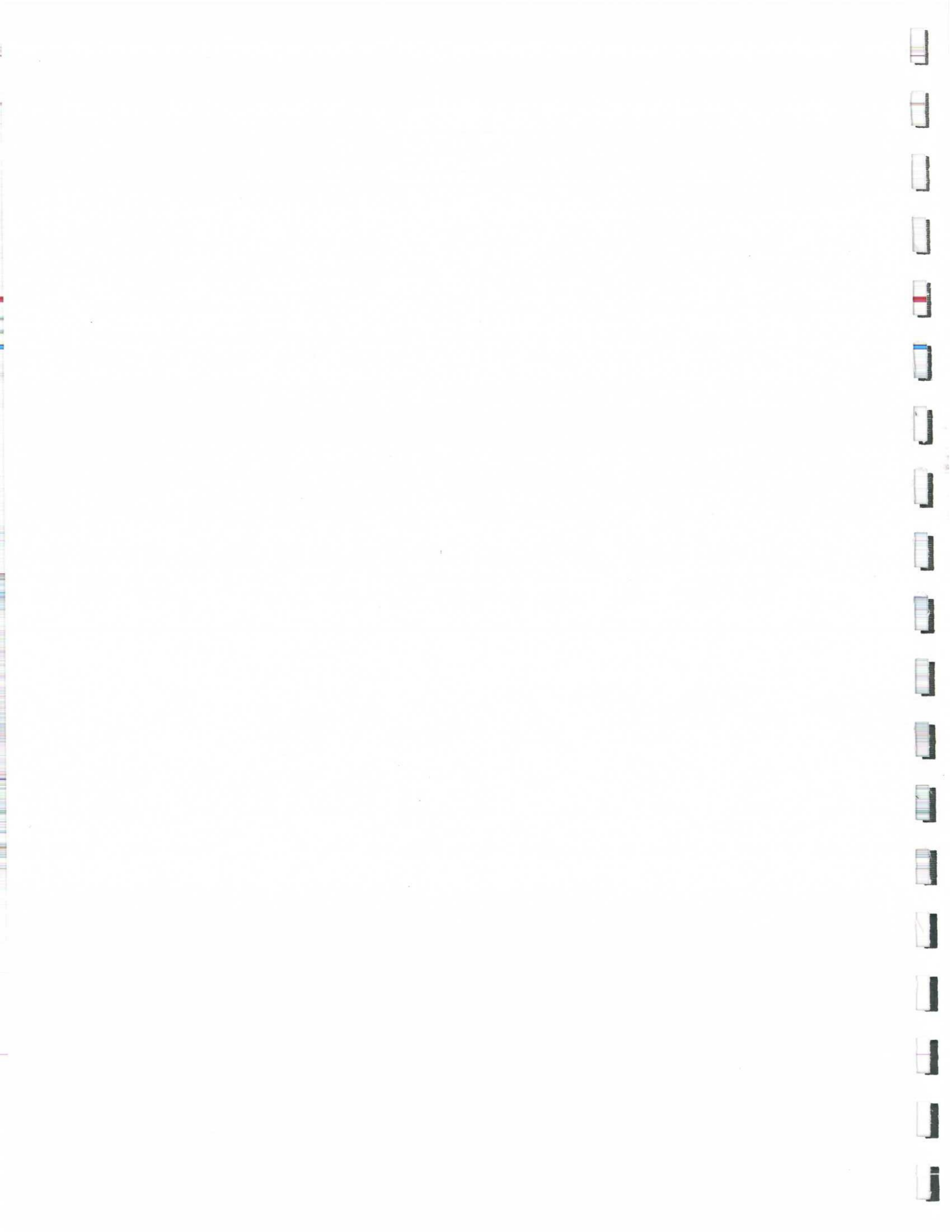
INLET NUMBER	T.C.	I	AREA ACRES	C	CA	Q	Q	GUTTER SLOPE	GUTTER VELOCITY	GUTTER SPREAD	INLET TYPE	INLET CAPACITY	FLOW BY	REMARKS

DELAWARE COUNTY INDIANA	STANDARD STORM DRAINAGE DESIGN INLET AND GUTTER CAPACITY
REVISED	
	DD 70



APPENDIX B





CERTIFICATE OF SUFFICIENCY OF PLAN

Permit Number: \_\_\_\_\_

Address, or location, where land alteration is occurring: \_\_\_\_\_

\_\_\_\_\_  
\_\_\_\_\_

Date of Drainage Plan: \_\_\_\_\_

I hereby certify that to the best of my knowledge and belief as follows:

1. The drainage plan for this project is in compliance with drainage requirements as set forth in the Storm Drainage and Sediment Control Ordinance for Delaware County, Indiana, pertaining to this class of work.

2. The calculations, designs, reproducible drawings, masters and original ideas reproduced in this drainage plan are under my dominion and control and they were prepared by me and/or my employees.

Signature: \_\_\_\_\_ Date: \_\_\_\_\_

Typed/Printed Name: \_\_\_\_\_

(Seal)

Business Address: \_\_\_\_\_

Surveyor: \_\_\_\_\_ Engineer: \_\_\_\_\_ Architect: \_\_\_\_\_

Indiana Registration Number: \_\_\_\_\_





CERTIFICATE OF OBLIGATION TO OBSERVE

Permit Number: \_\_\_\_\_

Address, or location, where land alteration is occurring: \_\_\_\_\_

\_\_\_\_\_

\_\_\_\_\_

Date of Drainage Plan: \_\_\_\_\_

I will perform periodic observations of this project during construction to determine that such land alteration is in accordance with both the applicable drainage requirements and the drainage plan for this project submitted for a drainage permit to the County Engineer's Office of Delaware County, Indiana.

Signature: \_\_\_\_\_ Date: \_\_\_\_\_

Typed/Printed Name: \_\_\_\_\_

Phone Number: \_\_\_\_\_

(Seal)

Business Address: \_\_\_\_\_

Surveyor: \_\_\_\_\_ Engineer: \_\_\_\_\_ Architect: \_\_\_\_\_

Indiana Registration Number: \_\_\_\_\_



CERTIFICATE OF COMPLETION AND COMPLIANCE

Permit Number: \_\_\_\_\_

Address, or location, of premises on which land alteration was accomplished: \_\_\_\_\_

Inspection Date(s): \_\_\_\_\_

Relative to plans prepared by: \_\_\_\_\_

Date of Drainage Plan: \_\_\_\_\_

I hereby certify that:

1. I am familiar with drainage requirements applicable to such land alteration as set forth in the Storm Drainage and Sediment Control Ordinance for Delaware County, Indiana; and

2. I have personally observed the land alteration accomplished pursuant to the above referenced drainage permit; and

3. To the best of my knowledge, information and belief such land alteration has been performed and completed in conformity with all such drainage requirements, except: \_\_\_\_\_

Signature: \_\_\_\_\_ Date: \_\_\_\_\_

Typed/Printed Name: \_\_\_\_\_

Phone Number: \_\_\_\_\_

(Seal)

Business Address: \_\_\_\_\_

Surveyor: \_\_\_\_\_ Engineer: \_\_\_\_\_ Architect: \_\_\_\_\_

Indiana Registration Number: \_\_\_\_\_





APPENDIX C





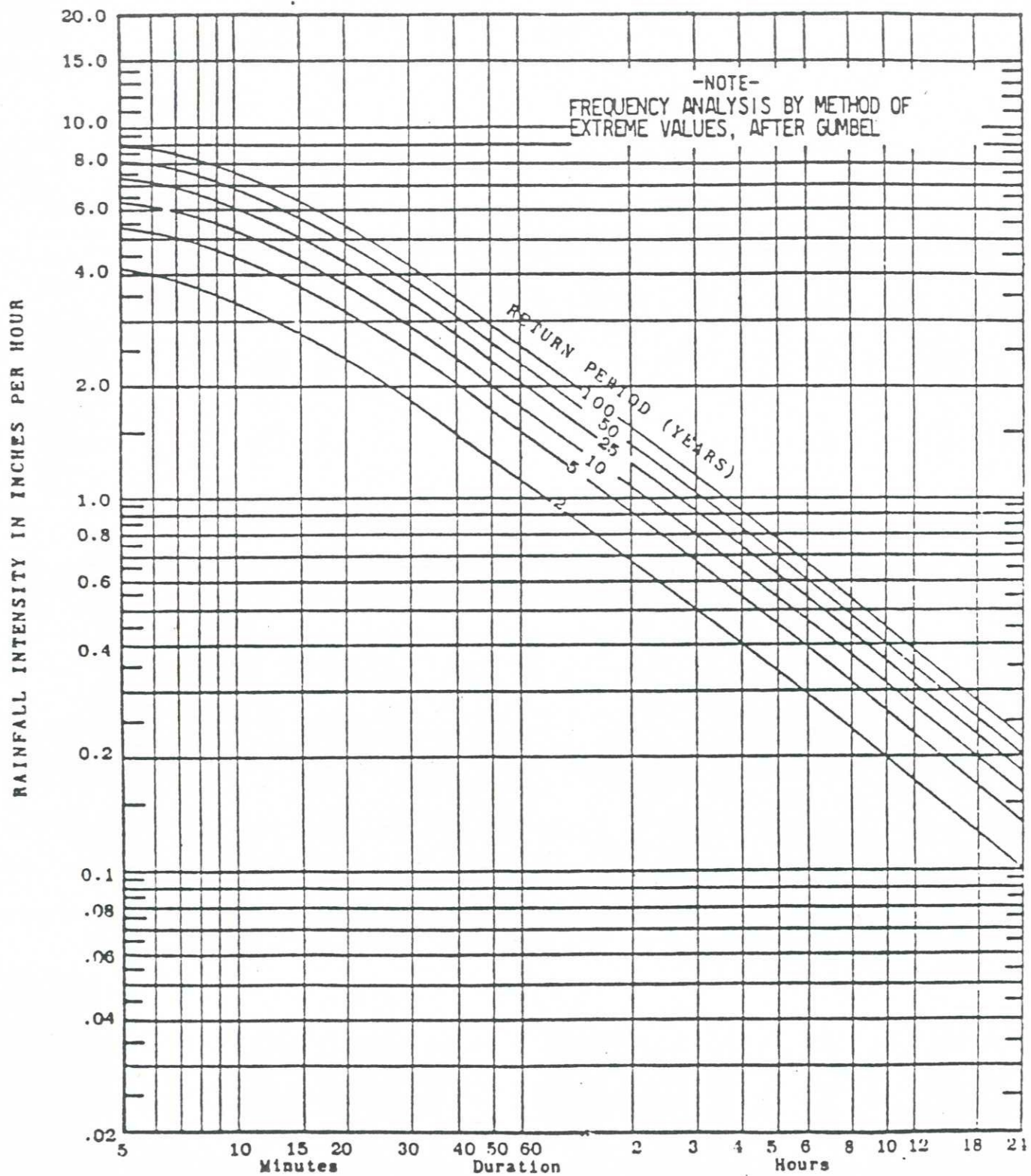


Figure 2.15 Rainfall Intensity-Duration-Frequency Curves

Fort Wayne, Indiana 1911 - 1951

(U.S. Department of Commerce - Weather Bureau - Cooperative Studies Section)



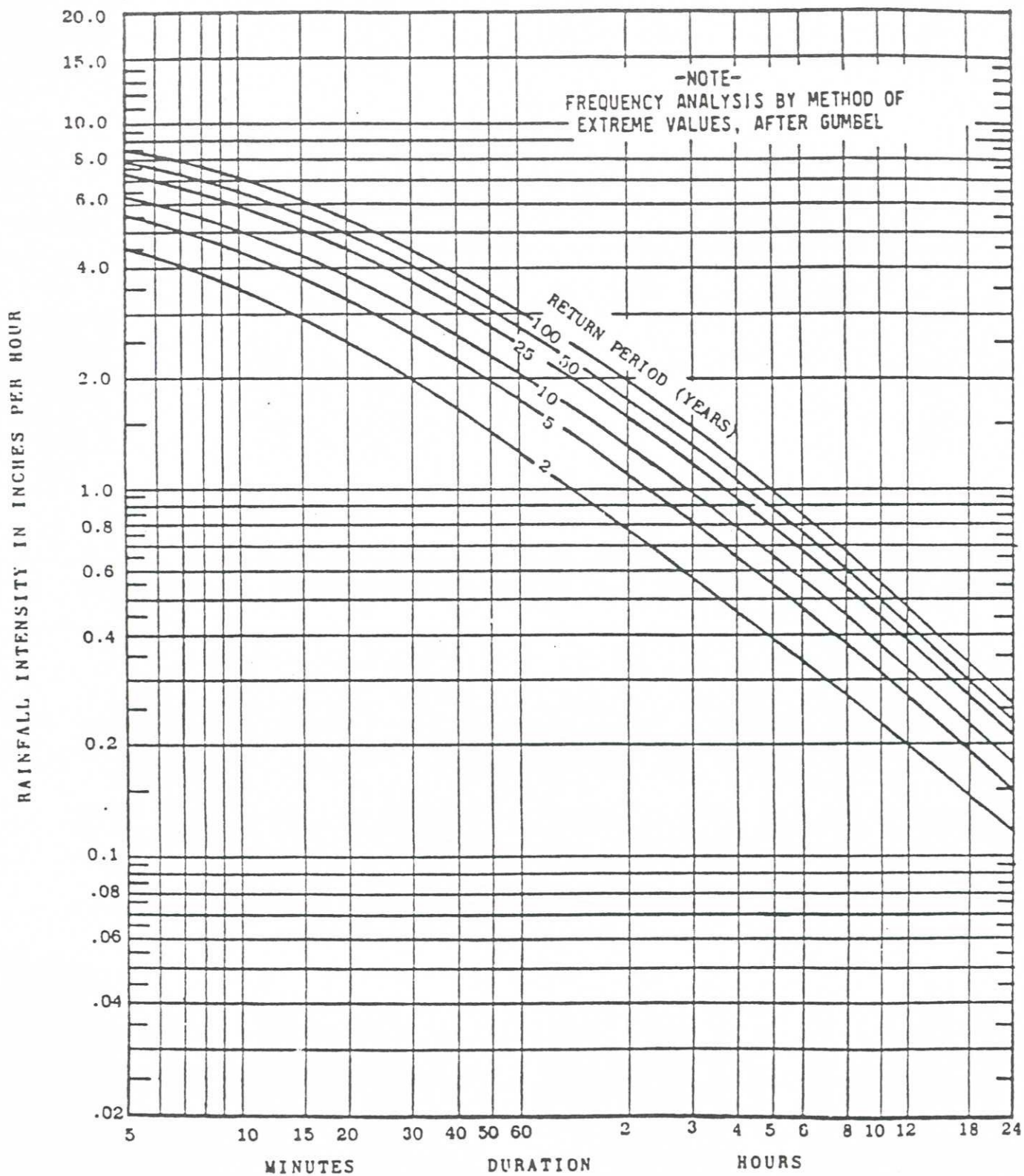


Figure 2.17 Rainfall Intensity-Duration-Frequency Curves  
Indianapolis, Indiana 1903 - 1951

(U.S. Department of Commerce - Weather Bureau - Cooperative Studies Section)





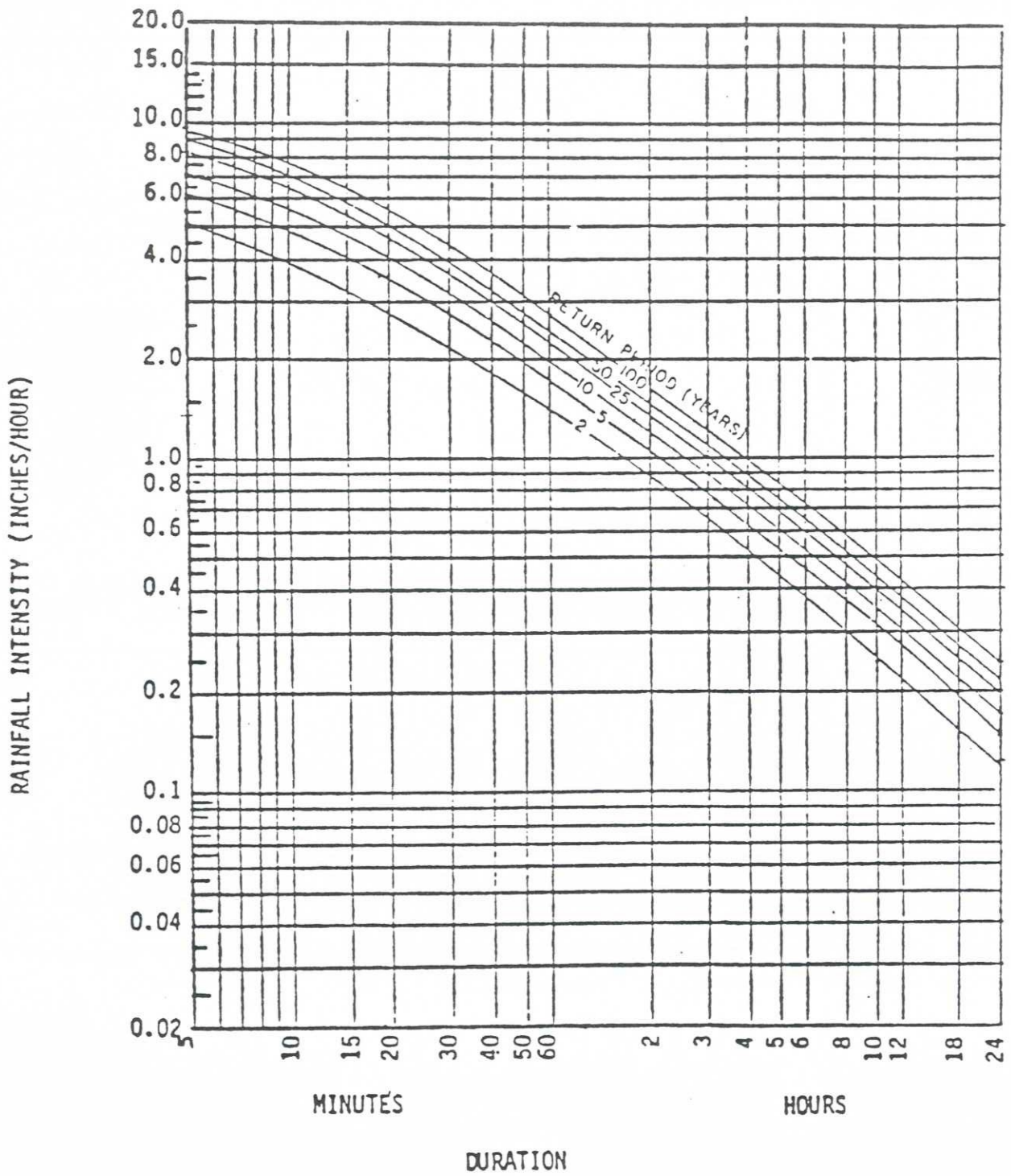


Figure 2.20 Rainfall Intensity-Duration-Frequency Curves  
West Lafayette, Indiana (Burke, 1979)





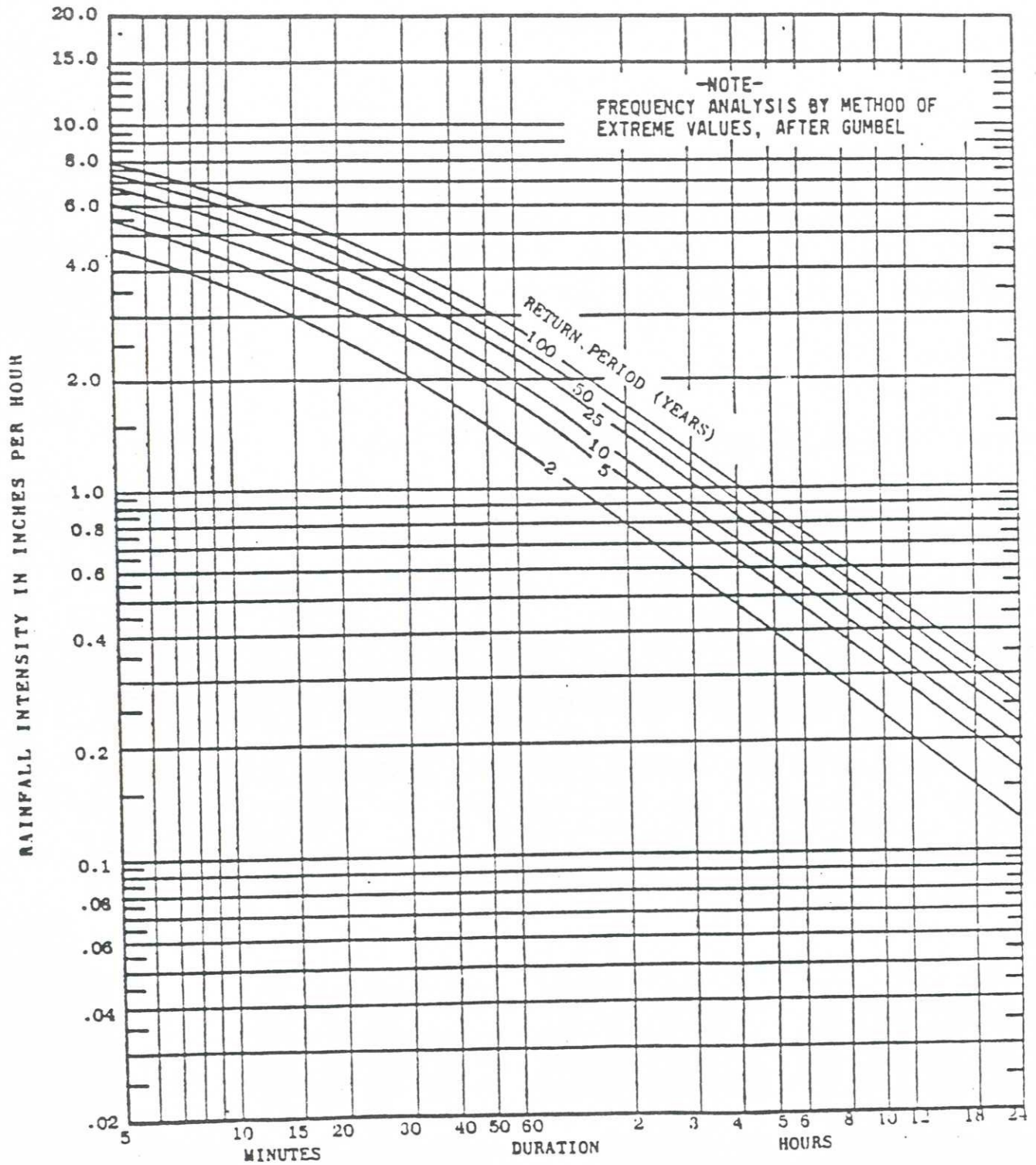


Figure 2.16 Rainfall Intensity-Duration-Frequency Curves  
Evansville, Indiana 1903 - 1951

(U.S. Department of Commerce - Weather Bureau - Cooperative Studies Section)



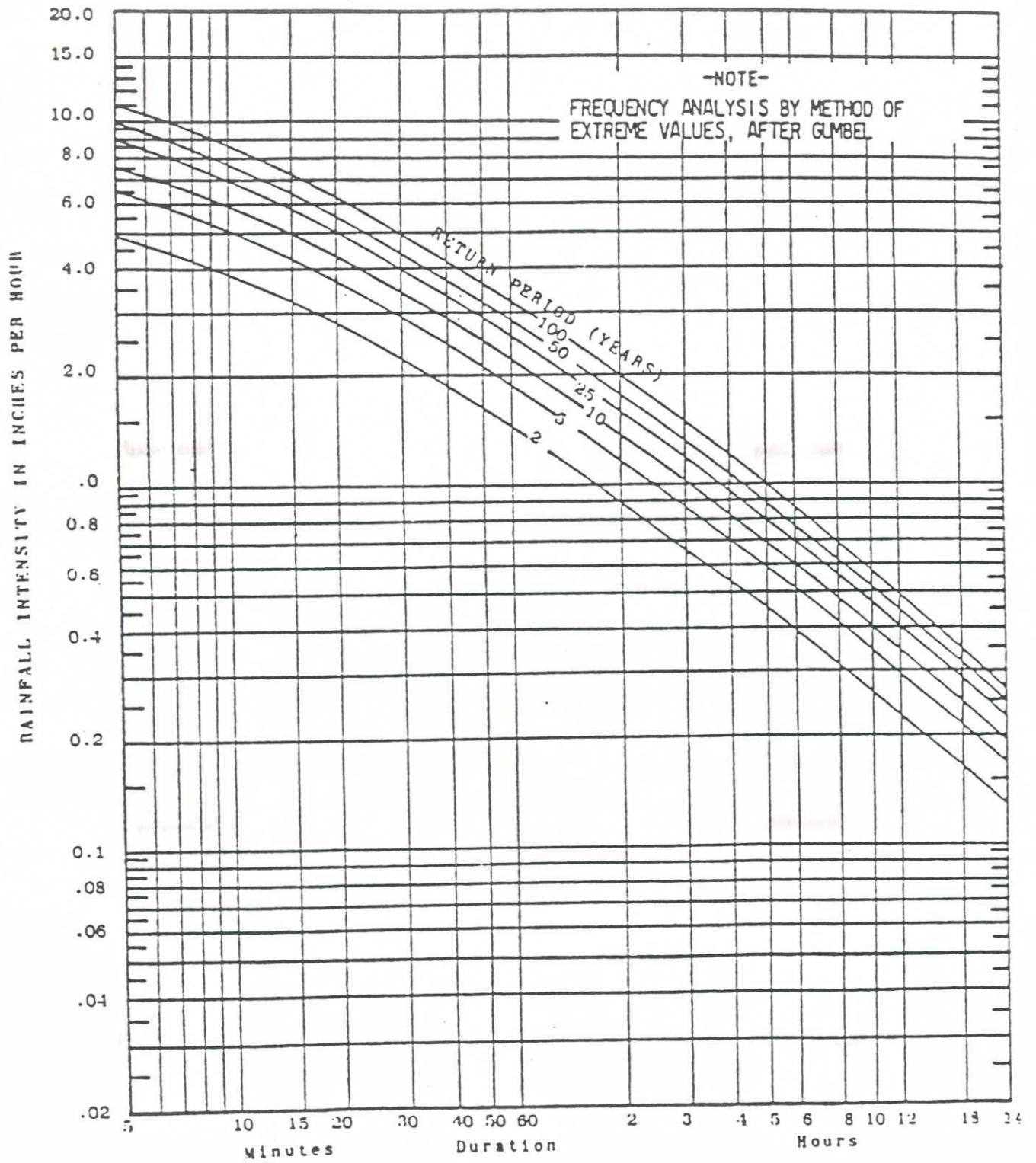


Figure 2.18 Rainfall Intensity-Duration-Frequency Curves  
Terre Haute, Indiana 1912 - 1951

(U.S. Department of Commerce - Weather Bureau - Cooperative Studies Section)

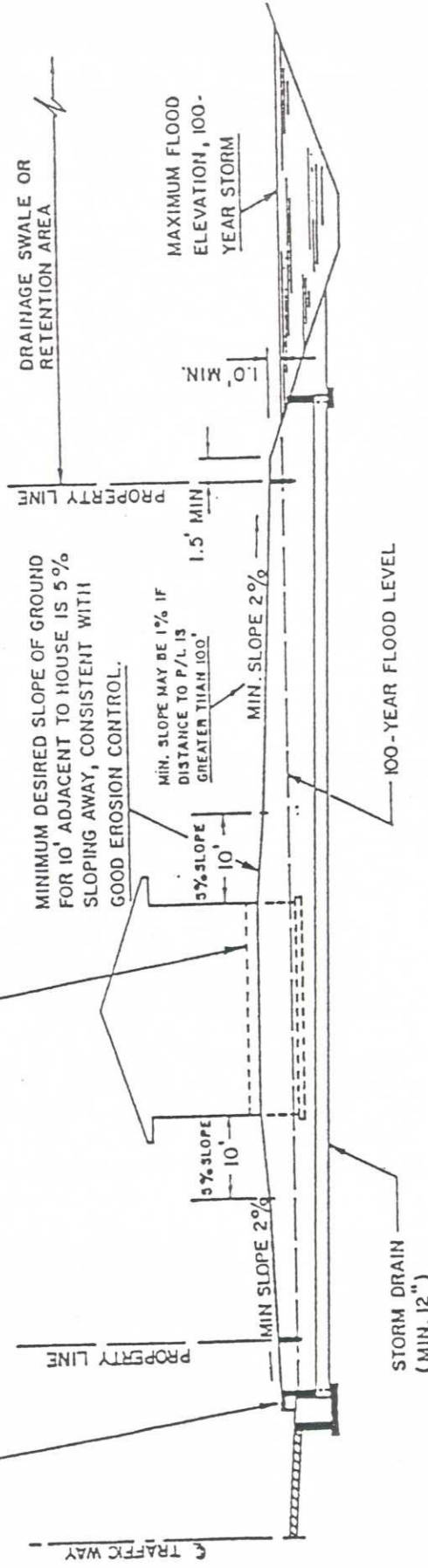


Faint, illegible text on a page with horizontal ruling lines. The text is too light to be transcribed accurately.



TOP OF CURB ( ESTABLISHED GRADE )  
 TO BE MINIMUM OF 1.5' ABOVE 100 - YEAR  
 FLOOD LEVEL OF SWALE AT REAR OF HOME.

FIRST FLOOR ENTRY TO BE A  
 MINIMUM OF 3' ABOVE THE  
 100 - YEAR FLOOD ELEVATION.



DELAWARE COUNTY  
 INDIANA

STANDARD GRADING PLAN  
 ONE - OR TWO - FAMILY DWELLING OR ACCESSORY  
 STRUCTURES

REVISED





APPENDIX D



## APPENDIX D

### DESIGN REFERENCE MATERIAL

1. "Design and Construction of Sanitary and Storm Sewers", ASCE Manual of Practice No. 37.
2. "Urban Storm Drainage Criteria Manual", Denver Regional Council of Governments, two volumes.
3. "Design Charts for Open Channel Flow", Hydraulic Design Series No. 3 by the U.S. Department of Transportation.
4. "Handbook of Concrete Culvert Pipe Hydraulics", Portland Cement Association.
5. "Handbook of Steel Drainage and Highway Construction Products", American Iron and Steel Institute.
6. "Design Manual Concrete Pipe", American Concrete Pipe Association.
7. "Hydraulic Charts for the Selection of Highway Culverts", Hydraulic Engineering Circular No. 5, U. S. Department of Transportation.
8. "Drainage of Highway Pavements", Hydraulic Engineering Circular No. 12, U.S. Department of Transportation.
9. "Inlet Grate Capacities", Neenah Foundry Company.
10. "Urban Hydrology for Small Watersheds", U.S. Soil Conservation Service, Technical Release No. 55, January, 1975 and Engineering Update No. 20, April, 1978.
11. "A Policy of Design and Urban Guidelines", American Association of State Highway and Transportation Officials, 1973.
12. "A Policy on Geometric Design of Rural Highways", American Association of State Highway and Transportation Officials, 1965.
13. "Engineering Field Manual for Conservation Practices", ENGIN-24, U.S. Department of Agriculture, Soil Conservation Service.
14. "The Indiana Drainage Code", State of Indiana, as amended.





15. "The Storm Drainage and Sediment Control Ordinance for Delaware County, Indiana", Delaware County, Indiana.
16. Indiana State Highway Standard Specifications.
17. "Soil Survey of Delaware County, Indiana", U. S. Soil Conservation Service.
18. Flood Insurance Rate Maps and Flood Boundary/Floodway Maps for Delaware County, Indiana, and all amendments thereto, prepared for Delaware County, Indiana, by the U. S. Corps of Army Engineers, Louisville, Kentucky, and the U. S. Department of Housing and Urban Development, Federal Insurance Administration.
19. "Design of Roadside Drainage Channels", Hydraulic Design Series No. 4, Bureau of Public Roads, 1965.
20. "Use of Riprap for Bank Protection", Hydraulic Engineering Circular No. 11, Bureau of Public Roads, 1961.
21. "Design of Small Dams", Bureau of Reclamation, U. S. Department of the Interior, Washington, D.C., 1960.
22. "Design Charts for Open-Channel Flow", Hydraulic Design Series No. 3, U. S. Department of Transportation, Federal Highway Administration.
23. "County Storm Drainage Manual", Highway Extension and Research Project for Indiana Counties (HERPIC), Christopher B. Burke, Purdue University, West Lafayette, Indiana, May, 1981.





DELAWARE COUNTY ENGINEER'S OFFICE  
DRAINAGE PLAN INSTRUCTIONS

DRAINAGE PLAN INCLUDES FORMS A, B, C, AND D.

PRIOR TO BEGINNING PROJECT:

1. SUBMIT 1 COPY OF COMPLETED APPLICATION (FORM A) AND 2 COPIES OF ALL DRAWINGS, CERTIFICATION FOR SUFFICIENCY OF PLAN (FORM B) AND OBLIGATION TO OBSERVE (FORM C).
2. REQUIREMENTS FOR DRAINAGE PLAN DRAWINGS:
  - A. Show a general area locator map.
  - B. Preferred scale for drainage plan map - 1" = 50'
  - C. Show north point, benchmarks and contours as follows:
    - <10% slope - 1' contours
    - >10% and <20% slope - 2' contours
    - >20% slope - 5' contours
  - D. Show all existing and proposed facilities, including all right of way and easement, with the following data:
    - coordinates for drains, manholes, etc.
    - direction of flow
    - elevation of inverts
    - gradients
    - sizes
    - capacities
    - grade
  - E. All profiles for drains and inlets should extend to the point of outfall and be at the following scale: 1" = 50' horizontal and 1" = 5' vertical
  - F. Show existing and proposed runoff conditions (basins and sub-basins, ground cover, soil types, inflow points of off site storm water, etc.) and flood plains and submit a soil map for the site in question.
  - G. Show all calculations including the following:
    - time of concentration for undeveloped condition
    - undeveloped runoff calculation (i.e. Cu)
    - developed runoff calculation
    - required storage
    - pipe sizes
    - invert slopes
    - roughness coefficients
    - velocities (fps)
    - capacities (cfs)
    - headloss - manholes/junction chambers
    - hydraulic gradient as applicable
    - erosion control measures
3. WITHIN TEN (10) DAYS AFTER COMPLETION, SUBMIT CERTIFICATION FOR COMPLETION AND COMPLIANCE (FORM D).

FOR YOUR INFORMATION

SUMMARY OF STANDARDS

Design Release Rate: 5 year Return Period for undeveloped condition or capacity of receiving facility - whichever is more restrictive

Design Storage Rate: 50 year Return Period for developed condition

Rational Method Maximum Runoff Coefficient: .20

Design Min. for Storm Sewer & Inlet System: 10 year Return Period > 1 hour time of concentration

Minimum Pipe Size: 12 inches (exception, see p. 19)

Minimum Sewer Velocity: 2.5 feet per second (fps)

Maximum Sewer Velocity: 15 feet per second (fps)

Minimum Depth of Cover: 3 feet (exception, see p. 19)

Manhole Locations: junctions; change in grade or direction

Max. Manhole Spacing: 400 feet for 12" - 42" sewers  
600 feet for >42" sewers

Encroachment of Runoff: 4 feet max. into streets with no parking  
12 feet max. or .35 feet depth for streets with parking

Inlet Locations: at low points, intersections and as needed to meet encroachment limits

Design Criteria for Culverts: 50 year Return Period for Principal & Minor Arterials and Major Collectors: 25 year Return Period for Minor Collector and local roads (No culvert shall carry less than existing capacity)

Open Channel Design: 50 year Return Period if carrying >30 cubic feet per second (cfs)

Desired Open Channel Velocity & Slopes: velocity - 3 feet per second slope - 3 : 1 (exceptions, see p. 23)

Design of Storage Facilities: see pp. 13-18

Examples of Computer Software: TR-55 (SCS runoff computations & design); HY-8 (culvert analysis); HEC-2 (channel flow profiles, effect on obstructions)

DELAWARE COUNTY ENGINEER'S OFFICE  
DRAINAGE PLAN APPLICATION FORM A

DATE FILED: \_\_\_\_\_

PERMIT NO.: \_\_\_\_\_

OWNER/DEVELOPER: \_\_\_\_\_

ADDRESS: \_\_\_\_\_ PHONE: \_\_\_\_\_

NAME OF PERSON WHO PREPARED PLANS, PROFILES AND CALCULATIONS:  
\_\_\_\_\_

BUSINESS ADDRESS: \_\_\_\_\_ PHONE: \_\_\_\_\_

\_\_\_\_\_ ENGINEER \_\_\_\_\_ SURVEYOR \_\_\_\_\_ ARCHITECT

INDIANA REGISTRATION NUMBER: \_\_\_\_\_

ADDRESS OF LOCATION WHERE WORK IS TO OCCUR: \_\_\_\_\_  
\_\_\_\_\_

LEGAL DESCRIPTION (insert or attach):

SAMPLE

NAME OF PARTY TO BE RESPONSIBLE FOR CONSTRUCTION:

ADDRESS: \_\_\_\_\_ PHONE: \_\_\_\_\_

NAME(S) OF PARTY TO BE RESPONSIBLE FOR MAINTENANCE AND FACILITIES AFTER  
CONSTRUCTION: \_\_\_\_\_  
\_\_\_\_\_

ADDRESS: \_\_\_\_\_ PHONE: \_\_\_\_\_

PERMIT ISSUED: \_\_\_\_\_ YES \_\_\_\_\_ NO DATE: \_\_\_\_\_

REASONS FOR NONISSUANCE: \_\_\_\_\_  
\_\_\_\_\_

AMOUNT OF PERMIT FEE PAID: \_\_\_\_\_

DATE OF DRAINAGE PLAN: \_\_\_\_\_

REVISIONS - DATES: \_\_\_\_\_





CERTIFICATE OF SUFFICIENCY OF PLAN  
FORM B

Permit Number: \_\_\_\_\_

Address of location where land alteration is occurring: \_\_\_\_\_  
\_\_\_\_\_  
\_\_\_\_\_

Date of Drainage Plan: \_\_\_\_\_

I hereby certify that to the best of my knowledge and belief as follows:

1. The drainage plan for this project is in compliance with drainage requirements as set forth in the Storm Drainage and Sediment Control Ordinance for Delaware County, Indiana, pertaining to this class of work.
2. The calculations, designs, reproducible drawings, masters and original ideas reproduced in this drainage plan are under my dominion and control and they were prepared by me and/or my employees.

Signature: \_\_\_\_\_ Date: \_\_\_\_\_

Typed/Printed Name: \_\_\_\_\_

(Seal)

SAMPLE

Business Address: \_\_\_\_\_

Surveyor: \_\_\_\_\_ Engineer: \_\_\_\_\_ Architect: \_\_\_\_\_

Indiana Registration Number: \_\_\_\_\_





CERTIFICATE OF OBLIGATION TO OBSERVE  
FORM C

Permit Number: \_\_\_\_\_

Address, or location, where land alteration is occurring: \_\_\_\_\_  
\_\_\_\_\_

Date of Drainage Plan: \_\_\_\_\_

I will perform periodic observations of this project during construction to determine that such land alteration is in accordance with both the applicable drainage requirements and the drainage plan for this project submitted for a drainage permit to the County Engineer's Office of Delaware County, Indiana.

Signature: \_\_\_\_\_ Date: \_\_\_\_\_

Typed/Printed Name: \_\_\_\_\_

Phone Number: \_\_\_\_\_

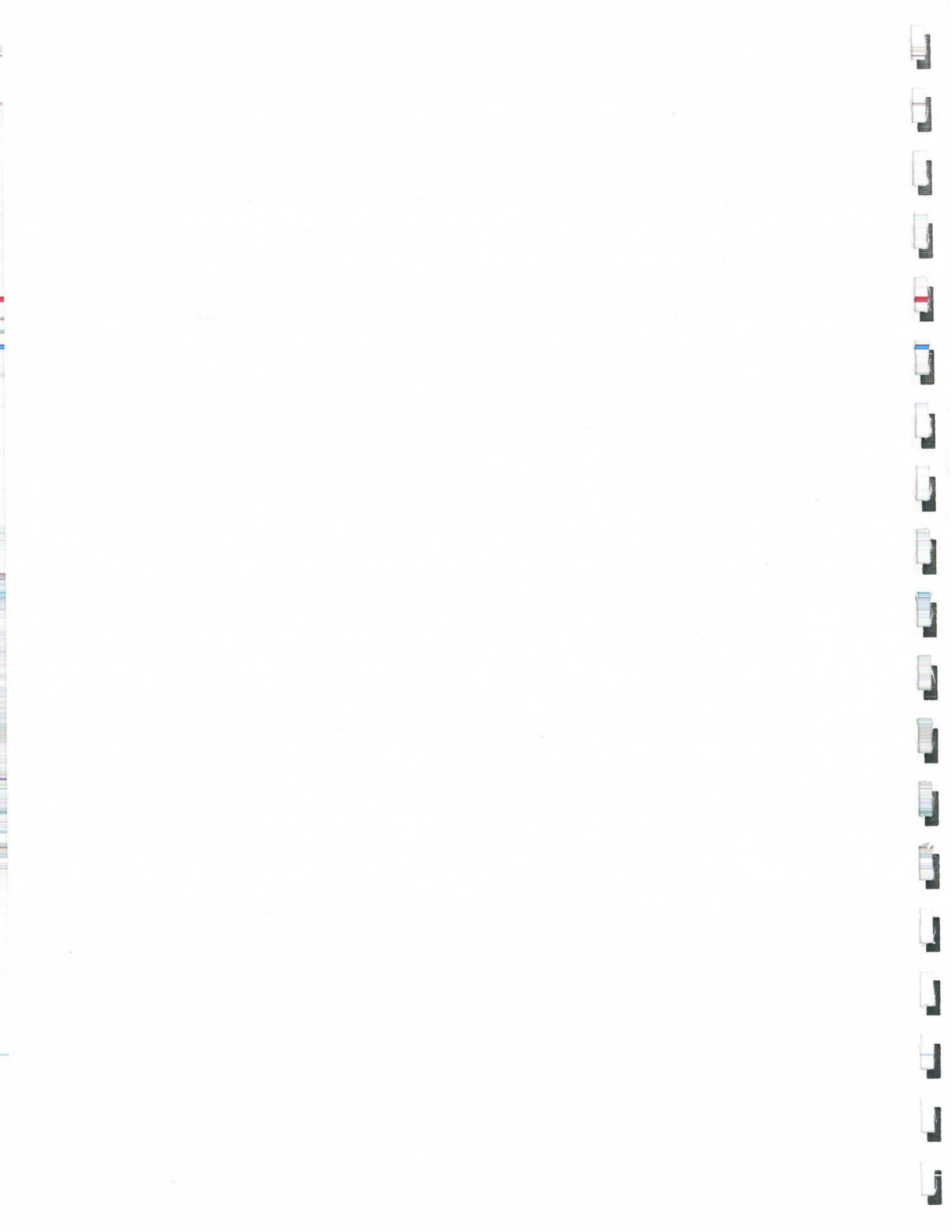
SAMPLE

(Seal)

Business Address: \_\_\_\_\_

Surveyor: \_\_\_\_\_ Engineer: \_\_\_\_\_ Architect: \_\_\_\_\_

Indiana Registration Number: \_\_\_\_\_



CERTIFICATE OF COMPLETION AND COMPLIANCE  
FORM D

Permit Number: \_\_\_\_\_

Address, or location, of premises on which land alteration was  
accomplished: \_\_\_\_\_

Inspection Date(s): \_\_\_\_\_

Relative to plans prepared by: \_\_\_\_\_

Date of Drainage Plan: \_\_\_\_\_

I hereby certify that:

1. I am familiar with drainage requirements applicable to such land alteration as set forth in the Storm Drainage and Sediment Control Ordinance for Delaware County, Indiana; and
2. I have personally observed the land alteration accomplished pursuant to the above referenced drainage permit; and
3. To the best of my knowledge, information and belief such land alteration has been performed and completed in conformity with all such requirements except: \_\_\_\_\_

Signature: \_\_\_\_\_ Date: \_\_\_\_\_

Typed/Printed Name: \_\_\_\_\_

Phone Number: \_\_\_\_\_

(Seal)

SAMPLE

Business Address: \_\_\_\_\_

Surveyor: \_\_\_\_\_ Engineer: \_\_\_\_\_ Architect: \_\_\_\_\_

Indiana Registration Number: \_\_\_\_\_

